



**PASCAL<sup>®</sup> Synthesis<sup>™</sup>**  
**(SL-PA04 single 532 nm / 577 nm)**

**Ophthalmic Scanning Laser System**  
**Operator Manual**

European Authorized Representative  
Obelis  
Boulevard Général Wahis 53  
1030 Brussels  
Belgium  
Phone: +32.2.732.59.54  
Fax: +32.2.732.60.03  
[www.obelis.net](http://www.obelis.net)

Iridex Corporation  
1212 Terra Bella Avenue  
Mountain View, CA 94043  
USA  
Office: +1.650.940.4700  
Fax: +1.650.962.0486  
[www.iridexretina.com](http://www.iridexretina.com)

**C €0044**

PASCAL Synthesis System Software 3.6.1

Caution: "Federal law restricts this device to sale by or on the order of a physician"

Intentionally left blank

---

This manual is copyrighted with all rights reserved. Under the copyright laws, this manual may not be copied in whole or in part or reproduced in any other media without the express written permission of Iridex Corporation. Permitted copies must carry the same proprietary and copyright notices as were affixed to the original under the law. Copying includes translation into another language.

Please note that while every effort has been made to ensure that the data given in this document is accurate, the information, figures, illustrations, tables, specifications and schematics contained herein are subject to change without notice.

Iridex Corporation®, the Iridex Corporation Logo™ and PASCAL® are trademarks or registered trademarks of Iridex Corporation.

PASCAL Synthesis; PASCAL Synthesis Ophthalmic Scanning Laser System are trademarks of Iridex Corporation.

PASCAL Synthesis refers to a family of laser products: single wavelength 532 nm and single wavelength 577 nm.

Intentionally left blank

---

## INTRODUCTION

---

### INTENDED USE / INDICATIONS FOR USE

PASCAL® Synthesis Ophthalmic Scanning Laser System is a laser system console with an integrated slit lamp. The system connects to the slit lamp to enable laser energy to be delivered through the slit lamp illumination path. The system may be used for standard single shot photocoagulation and laser scanning patterns.

The system enables the physician to deliver multiple laser spots with a single footswitch depression by automating the emission of laser light. The aiming beam displays the pattern, allowing the physician to place it in the appropriate location.

The system is intended for use by trained Ophthalmologists for diagnosis and treatment of ocular pathology in both the posterior and anterior segments. Intended for use in the posterior segment to perform retinal photocoagulation, panretinal photocoagulation, focal photocoagulation and grid photocoagulation for vascular and structural abnormalities of the retina and choroid including:

(532 nm)

- proliferative and non-proliferative diabetic retinopathy
- macular edema
- choroidal neovascularization associated with wet age-related macular degeneration
- age-related macular degeneration
- lattice degeneration
- retinal tears and detachments (577 nm)
- proliferative and non-proliferative diabetic retinopathy
- macular edema
- choroidal neovascularization associated with wet age-related macular degeneration
- age-related macular degeneration
- lattice degeneration
- retinal tears and detachments

Intended for use in the treatment of ocular pathology in the anterior segment including: (532 nm and 577 nm)

- iridotomy
- trabeculoplasty

## **FEATURES**

PASCAL Synthesis Ophthalmic Scanning Laser System is a laser system console with an integrated slit lamp. The system connects to the slit lamp to enable laser energy to be delivered through the slit lamp illumination path. The system may be used for standard single shot photocoagulation and laser scanning patterns.

PASCAL Synthesis Ophthalmic Scanning Laser System enables the physician to deliver multiple laser spots with a single footswitch depression by automating the emission of laser light. The aiming beam displays the pattern, allowing the physician to place it in the appropriate location.

---

## **PURPOSE OF THIS MANUAL**

This manual outlines PASCAL Synthesis Ophthalmic Scanning Laser System, including operating procedures, troubleshooting, maintenance and cleaning. Please refer to this operator manual for instructions and guidance on how to appropriately use your laser.

Before using the system, carefully read “CAUTION & WARNING” and “General Safety and Regulatory Information” section to familiarize yourself with the operation of the system.

---

## **ATTENTION**

Iridex Corporation accepts full responsibility for safety, reliability and performance of the device only if:

- Service, readjustments, modifications and/or repairs are performed exclusively by Iridex Corporation-certified personnel.
- The electrical installation of the treatment room complies with the applicable IEC, CEC and NEC requirements.

The warranty is void if any of these warnings are disregarded.

Iridex Corporation reserves the right to make changes to the device(s) herein. Device(s), therefore, may not agree in detail with the published design or specifications. All specifications are subject to change without notice.

For questions regarding your laser, please contact Iridex Corporation or your local Iridex Corporation representative.

# Table of Contents

INTRODUCTION.....	5
INTENDED USE / INDICATIONS FOR USE.....	5
Table of Contents.....	7
CAUTIONS & WARNINGS.....	10
Disclaimer.....	11
Console Labels.....	11
Additional Labels.....	14
Operator Manual Symbol Definitions.....	15
General Safety and Regulatory Information.....	15
Ocular Protection.....	16
Laser Safety Eyewear.....	17
Electrical Hazards.....	18
Non Homogeneous Pattern Delivery.....	19
Fiber Optic Cable Assembly.....	19
Pattern Titration.....	19
Titration.....	20
Fire Hazard.....	20
Protecting Non-target Tissues.....	21
Operational Safety.....	21
Additional Safety Considerations.....	24
Regulatory Compliance Safety Features.....	25
Key Lock Switch.....	25
Laser Emission Indicator.....	25
Door Interlock.....	25
Emergency Stop.....	25
Protective Housing.....	25
Safety Interlocks.....	25
Safety Shutter.....	25
Location of Controls.....	26
Manual Reset.....	26
Electrical Fault Detection Circuitry.....	26
Location of Regulatory and Other System Labels.....	26
Ophthalmic Applications.....	26
Contraindications.....	28
Potential Complications or Side Effects.....	28
Adverse Effects and Complications.....	29
Posterior Segment Laser Procedures.....	29
Anterior Segment Laser Procedures.....	29
System Components.....	31
Laser Console.....	31
Touchscreen LCD Control Panel.....	31
Slit Lamp (model SL-PA04).....	32
Footswitch.....	32
Door Interlock Plug.....	32
Micro Manipulator.....	33
Power Knob.....	33
3D Controller (Purchased Separately).....	34

3D Controller Action .....	34
LIO (Laser Indirect Ophthalmoscope) – optional accessory.....	35
System Installation and Setup.....	36
Connecting the System Components.....	37
System Start-up and Shut-down .....	39
Starting the System .....	39
Shutting Down the System (Standard Shut-down).....	39
Emergency Shut-down .....	39
Control Screen Description .....	40
Home Screen.....	40
Posterior Treatment Screen .....	41
Anterior Treatment Screen .....	46
Posterior Pattern Descriptions/Pattern Parameters.....	49
Single Spot .....	50
Array .....	51
Triple Ring .....	60
Line.....	61
Hexagon .....	75
Single Spot .....	76
Anterior Pattern Descriptions/Pattern Parameters .....	78
Array .....	79
Pattern Titration .....	80
Endpoint Management with Landmark Patterns (optional).....	82
System Software Setup.....	84
System Setup Screen.....	84
Patient Information Feature.....	86
Progressive Titrate .....	88
<Physician Preferences> Window.....	88
<Edit Physician Preferences> Window .....	89
Contact Lens Selection Screen .....	90
Favorites Window .....	91
<Edit Favorites> Window.....	93
Treatment Report Window.....	95
Export Treatment Report .....	97
Procedure to prepare the USB drive before the first time use.....	98
Treatment Reports.....	99
Intraoperative Instructions .....	103
Slit Lamp Treatment Procedure.....	103
LIO Treatment Procedure.....	104
Between Patient Treatments .....	105
System Shut-down .....	105
Maintenance Instructions .....	106
Annual Maintenance.....	106
System Repair .....	106
User Maintenance .....	106
Cleaning the Console External Surfaces.....	106
Cleaning the Control Panel Screen .....	106
Maintaining Effectiveness of Grounds .....	106
Replacing the Fuses.....	107
System Specifications .....	108
Troubleshooting Guide .....	111

System does not turn on.....	112
Error Messages .....	115
Calibration Procedure.....	122
Disclaimer Warning .....	122
Calibration Instructions .....	122
System Relocation Instructions .....	123
Room Preparation .....	123
Instructions for Use .....	124
Intended Use Environment .....	124
Patient Environment .....	124
Electromagnetic Compatibility .....	126
Ophthalmology References.....	132
General information on Usage .....	133
Intended Patient Population .....	133
Intended User Profile.....	133
Accessories .....	133
<b>Warranty Information</b> .....	134
Warranty Shipments, Returns, and Adjustments.....	134
Decontamination of Returned Equipment .....	135
US Technical Service Information .....	135
Decontamination Certification .....	136
Disposal.....	137
Pattern Scanning Laser Trabeculoplasty (PSLT) (optional).....	138
Anterior Pattern Descriptions/Pattern Parameters .....	140
Array.....	141
PSLT 3 Row .....	142

# **CAUTIONS & WARNINGS**

## Disclaimer

Calibration of the PASCAL Synthesis Ophthalmic Scanning Laser System is a service procedure to be performed only by Iridex Corporation-certified personnel or customers who have taken and passed a Iridex Corporation Bio-Medical Preventative Maintenance Training course on the appropriate laser system. Adjustment by anyone other than Iridex Corporation-certified personnel or by customers who have taken and passed a Bio-Medical Preventative Maintenance Training course voids any existing manufacturer's warranty on the instrument and can result in serious personal injury.

## Console Labels

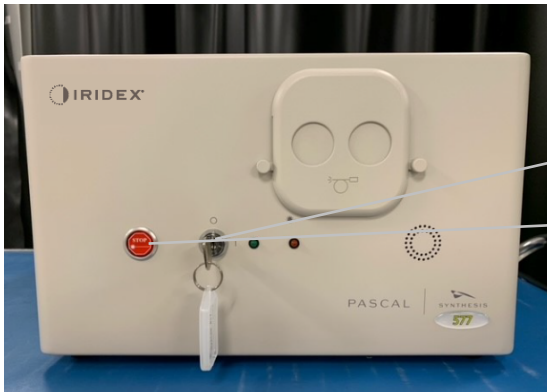

- 1. Key Switch Position
- 2. Emergency Stop Button and Label



- 3. European Representative Label
- 4. System Information Label
- 5. Danger Label
- 6. Laser Radiation Caution Label
- 7. Component Connections





PASCAL Synthesis (577nm)

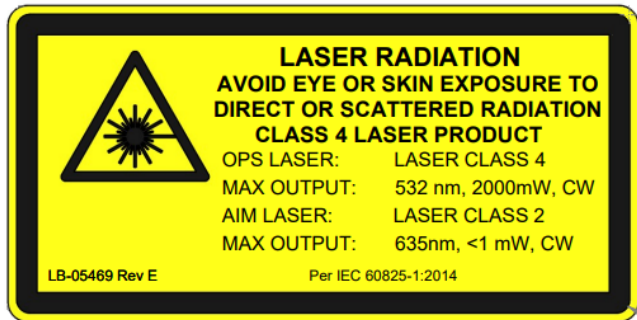

PASCAL Synthesis (532 nm)

**Laser Radiation Caution Label, includes:**

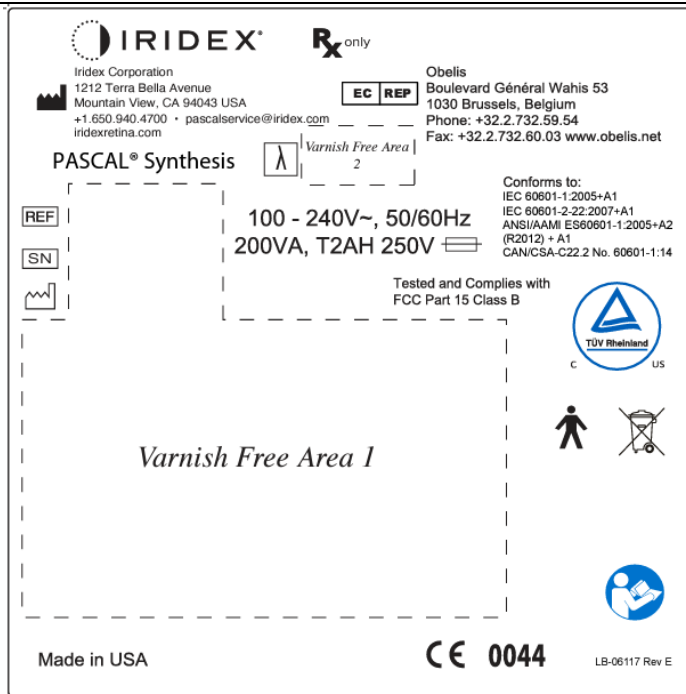
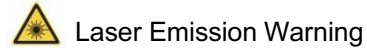



PASCAL Synthesis

**System Information Label, includes:**

- Manufacturer
- Part Number
- Serial Number
- Manufacture Date
- Follow operating instructions
- WEEE Directive
- Type B applied part
- $\lambda$  Wavelength (nm)
- Rx ONLY Prescription Only
- European Representative

	<p><b>Caution, Class 4 Laser Emission</b></p> <p>Laser beam may be present in this area, when opened.</p>
<div style="text-align: center;"> <p><i>PASCAL Synthesis (532 nm)</i></p> </div> <div style="text-align: center; margin-top: 20px;"> <p><i>Pascal Synthesis (577 nm)</i></p> </div>	<p><b>Danger label, includes:</b></p> <ul style="list-style-type: none"> <li>• Laser Emission Warning</li> <li>• Wavelength</li> <li>• Power</li> <li>• Laser Class</li> </ul>
	<p>USB Connections</p>
	<p>Wireless USB Caution</p>
	<p>Remote Door Interlock Connection</p>
	<p>Footswitch Connection</p>
<p>I</p> <p>O</p>	<p>ON</p> <p>OFF</p>





	<p><b>Laser Aperture Label</b></p> <p>Laser Emission Warning</p>
	<p><b>Warning, Hot Surface Label</b></p> <p>Warning, this surface may be extremely hot.</p>
	<p><b>General Warning Label</b></p>

**Additional Labels**

	<p><b>Footswitch</b></p> <p>Ingress Protection</p>
<p><b>Hospital Grade Cord:</b> Grounding reliability can be achieved when equipment is connected to an equivalent Receptacle marked "Hospital Grade" or "Hospital only"</p>	<p><b>"Hospital Grade" Cord Grounding Instructions</b></p>

## Operator Manual Symbol Definitions

Please read this manual and follow its instructions carefully. These words **WARNING & CAUTION** and **NOTE** carry special meanings and should be carefully reviewed.

	<p><b>CAUTION</b></p>	<p>Alert the user to use special care necessary for the safe and effective use of the device. They may include actions to be taken to avoid effects on patients or users that may not be potentially life threatening or result in serious injury, but about which the user should be aware. Cautions are also provided to alert the user to adverse effects on this device of use or misuse and the care necessary to avoid such effects.</p>
	<p><b>WARNING</b></p>	<p>Alert the user to potential serious outcomes (death, injury, or serious adverse events) to the patient or the user.</p>
	<p><b>LASER WARNING</b></p>	<p>Warning specifically related to hazard from a laser beam</p>
	<p><b>DANGEROUS WARNING</b></p>	<p>Warning specifically related to a hazard from electricity</p>
	<p><b>NOTE</b></p>	<p>Provided when additional general information is applicable.</p>

## General Safety and Regulatory Information

Iridex Corporation laser systems are precision medical instruments. The systems have undergone extensive testing. With proper handling, they are useful and reliable clinical instruments. To protect operating personnel and patients, this safety section and the appropriate slit lamp and pattern generator delivery system safety section should be read thoroughly before operation.

Iridex Corporation lasers are classified as Class IV lasers by the National Center for Devices and Radiological Health. Class IV represents the highest power lasers; for this reason, the user must take precautions to prevent exposure of laser energy to the eye and skin from either direct or diffusely reflected laser beams, except as a therapeutic application. In addition, precautions must be taken in the surgical environment to prevent the hazards of fire and electrical injury.

Iridex Corporation does not recommend specific clinical practices. The following precautions are extensive but may not be complete. Laser users are advised to supplement this information with technological advances in surgical products and techniques as they become available to the medical laser user community through medical literature. See also the American National Standard (ANSI) publications ANSI

Z136.3-2005—American National Standard for the Safe Use of Lasers in Health Care Facilities, ANSI Z136.1-2000—American National Standard for the Safe Use of Lasers, CAN/CSA-S386-2008—Laser Safety in Health Care Facilities and other national standards as may be applicable for the country in which the laser system is used.

This device complies with Part 15 of the FCC Rules. Operation is subject to the following two conditions: (1) This device may not cause harmful interference, and (2) this device must accept any interference received, including interference that may cause undesired operation.

## Ocular Protection



### **WARNING: LASER HAZARD**

*Never look directly into the laser aperture or scattered laser light from reflective surfaces when the treatment beam is activated. Severe eye damage could occur.*

*Never look into the path of a laser beam. Laser safety eyewear only offers protection against stray or diffuse laser beam energy for a maximum exposure of 10 seconds.*

*Never substitute glass prescription eyewear for the appropriate laser safety eyewear, as severe eye damage could occur. The glass in prescription eyewear can concentrate the laser light onto the retina. A high power density beam can also shatter glass prescription eyewear, resulting in possible severe eye damage.*

*Do not use eyewear that is broken or damaged.*

*The  (laser emission) indicator is displayed on the Treatment screen to warn the user that the system is capable of emitting laser energy. Appropriate precautions, such as wearing appropriate eyewear in the room, should be taken.*

*As a precaution against accidental exposure to the output beam or its reflection, anyone checking or adjusting calibration should wear appropriate laser safety eyewear.*

*Because prolonged intense light exposure can damage the retina, the use of the device for ocular examination should not be unnecessarily prolonged and the brightness setting should not exceed what is needed to provide clear visualization of the target structures.*

*The retinal exposure dose for a photochemical hazard is a product of the radiance and the exposure time. If the value of radiance were reduced in half, twice the time would be needed to reach the maximum exposure limit.*

*While no acute optical radiation hazards have been identified for slit lamps, it is recommended that the intensity of light directed into the patient's eye be limited to the minimum level that is necessary for diagnosis. Infants, aphakes and persons with diseased eyes will be at greater risk. The risk may also increase if the person being examined has had any exposure with the same instrument or any other ophthalmic instrument using a visible light source during the previous 24 hours. This will apply particularly if the eye has been exposed to retinal photography. The red diode laser aiming beam has an average*

power varying from barely visible to 1 mW maximum. The safe (Class II) exposure duration limit at a maximum power level of 1 mW is 3.9 seconds. To protect the patient from possible retinal damage during treatment, use the lowest practical aiming beam intensity and the minimal required time duration.

Using any of the larger patterns while the slit lamp magnification is set to 32X, may result in the pattern overflowing the visual field. Reduce the slit lamp magnification or adjust the pattern size. Do not attempt treatment unless the entire pattern is visible.

## Laser Safety Eyewear



### WARNING: LASER HAZARD

Laser safety eyewear is routinely required with most lasers. When using the system, the laser safety officer should determine the need for safety eyewear based on the Maximum Permissible Exposure (MPE), Nominal Hazard Zone (NHZ) and the Nominal Ocular Hazard Distance (NOHD) for each of the available laser wavelengths, as well as the wavelength itself and the configuration of the treatment room (usually within the controlled area).

ANSI Standard Z136.1-2007 defines MPE as “the level of radiation to which a person may be exposed without hazardous effect or adverse biological changes in the eye or skin”; the NHZ as “the space within which the level of direct, reflected or scattered radiation during normal operation is not expected to exceed the applicable MPE”; and the NOHD as “the distance along the axis of the unobstructed beam from the laser to the human eye beyond which the irradiance or radiant exposure during operation is not expected to exceed the appropriate MPE.”

The NOHD is measured from the slit lamp and pattern generator delivery system laser aperture. ANSI defines the controlled areas as “an area where the occupancy and activity of those within is subject to control and supervision for the purpose of protection from radiation hazards.”

**All personnel who are within the NOHD are considered to be in the controlled area and shall wear eye protection with the appropriate optical density. Eyewear must be resistant to physical damage and photo-bleaching. The minimum optical density (OD) is 4 at 532 nm or 577 nm; for countries inside Europe and that comply with EN 207, the eyewear must have a protection class of L5 at 532 nm or L4 at 577 nm.**

Delivery Device	NOHD (532 nm and 577 nm)
Slit Lamp	5.4 (17.7')
LIO	16.1 m (52.8')



## NOTE

*These ratings only apply to laser exposure greater than 200 mm (7.9 in) away from the laser exit aperture of the SLA.*

The type of eye protection recommended for the physician, the patient, and/or treatment room personnel within the NHZ depends on the planned procedure and the equipment required to perform that procedure.

An eye safety filter is provided with the SLA and is required for safe use. Laser safety eyewear is not required by the physician who views the procedure through the slit lamp eyepieces. All other personnel within the NHZ must wear laser safety eyewear with the recommended optical density.

Along with providing the appropriate safety eyewear, the following steps should be taken to secure the controlled area:

1. Treatment should be conducted in a dedicated, enclosed room.
2. A warning sign should be placed on the outside of the treatment room door when the laser is in use. The sign is intended to alert personnel before they enter the controlled area.
3. The treatment room door should be kept closed during treatment.

## Electrical Hazards



### WARNING: DANGEROUS VOLTAGE

*To avoid the risk of electric shock, this equipment must only be connected to a supply mains with protective earth. Hospital Grade Cord grounding reliability can only be achieved when equipment is connected to an equivalent receptacle marked "Hospital Grade" or "Hospital only".*

*To avoid the risk of electric shock, do not touch any external connector and the patient simultaneously.*

*Do not use power cables other than the power cable provided with the system. Do not use extension cables with the system.*

*Disconnect the laser system from the electrical outlet when inspecting the fuses.*

*Never open the laser console protective covers. Opening the covers will expose you to high voltage components, the laser resonator and possible laser radiation. Only certified personnel shall work inside the console.*

*The area around the laser and footswitch shall be kept dry. Do not operate the laser if any of the cords are faulty or frayed. The laser should undergo routine inspection and maintenance per the Iridex Corporation manufacturer's recommendation and institutional standards.*

## Non Homogeneous Pattern Delivery



### WARNING

The optical system in this unit has been designed to provide uniform laser energy deposition over the entire area of a focused spot. If proper focus of the laser spot on its intended target is not achieved, or if damage, contamination, or deterioration of the optical components has occurred, it is also possible to degrade this uniformity. Observation of aiming laser spots should provide suitable indication of the level of uniformity attainable in any given system configuration, and treatment should proceed only when the user is satisfied as to the level of laser deposition uniformity by observation of properly focused aiming laser spots. Service personnel should be contacted for any concerns in this regard.

Treatment with laser deposition that is highly non-uniform can result in localized over- and/or under-treatment of the affected areas.

The larger the pattern, the more likely that spots within the pattern would be non-uniformly delivered. Smaller pattern sizes may be less likely to produce non-homogeneous lesions than larger patterns.

There are other variables which may contribute to non-uniform pattern laser application, including, but not limited to the following: media opacities (i.e. cataract) and heterogeneity within a particular opacity; ischemic retinal changes; other situations where there is no visible retinal/media non-homogeneity.

## Fiber Optic Cable Assembly



### WARNING: LASER HAZARD

*Use extreme care with the cable assembly to/from the console. The cable assembly consists of wiring and fiber optic cables.*

*Do not pull or stress any cables. Do not exceed bend radius of 15cm Do not set items on or under the cable assembly.*

*Damage to the fiber optic cables may cause unintended laser exposure.*

## Pattern Titration



### WARNING

*The Physician is expected to show discretion in the dosage and location of the laser delivery when using the Pattern Titration feature. It is the responsibility of the physician to select the appropriate power and treatment location.*

Please note that when retrieving a favorite that has been saved in titration mode, the values of the pattern parameters that are not allowed to be changed in titration will be restored to the defaults.

## Titration



### WARNING

A single titration session at the very beginning of a treatment may be insufficient, as different areas of tissue may respond differently over the course of the treatment. Uniform tissue response should be continuously assessed by the end-user and re-titration may be necessary during the procedure.

Please confirm that Endpoint MGMT is automatically disabled and grayed out during titration mode .

Attempting to perform titration when EndPoint Management is turned on may result in overpower exposure.

## Fire Hazard



### WARNING

Do not use the laser system in the presence of flammables or explosives such as volatile anesthetics, alcohol, certain surgical preparation solutions or other such substances. An explosion and/or fire could occur.

Do not use in an oxygen-rich environment.

The treatment beam can ignite most nonmetallic materials. Use fire retardant drapes and gowns. The area around the treatment site can be protected with towels or gauze sponges moistened with sterile saline solution or sterile water. If allowed to dry, protective towels and sponges can increase the potential fire hazard. A UL-approved fire extinguisher should be readily available.

Per IEC 60601-2-22: The use of flammable anesthetics or oxidizing gases such as nitrous oxide (N<sub>2</sub>O) and oxygen should be avoided. Some materials (e.g., cotton wool) when saturated with oxygen may be ignited by the high temperatures produced in normal use of the system. The solvents of adhesives and flammable solutions used for cleaning and disinfecting should be allowed to evaporate before the laser system is used. Attention should also be drawn to the danger of ignition of endogenous gases.

## Protecting Non-target Tissues



### **WARNING: LASER HAZARD**

*Never place hands or other objects in the path of the laser beam. Severe burns could occur.*

*Except during actual treatment, the system must always be in STANDBY mode. Maintaining the system in STANDBY mode prevents accidental laser exposure if the footswitch is inadvertently depressed.*

*Only the person aiming the laser beam should have access to the footswitch. Use caution depressing the footswitch when it is in proximity to a footswitch for other equipment. Make sure the footswitch depressed is the correct one to avoid accidental laser exposure.*

## Operational Safety



### **WARNING**

*Read this operating manual thoroughly and be familiar with its contents prior to using this equipment.*

*If excessive or unintended eye movement is a concern, treatment is not recommended.*

*Exercise caution while setting treatment parameters (for example exposure time and the number of spots per pattern) when laser burns are to be delivered in the non-macular area for long time periods leading to longer grid completion times. Please be aware that with longer completion times, the possibility of patient movement increases the risk of treatment of unintended targets.*

*Verify eye safety filter is properly attached to the slit lamp prior to use.*

*Always verify the power settings on the screen prior to pressing the footswitch.*

*Verify adjustments to laser parameters on the monitor before pressing the footswitch.*

*Verify that the slit lamp eyepieces are adjusted to your settings before each use, especially in a multi-user practice. Only when the eyepieces are properly adjusted is the laser confocal with the microscope. The laser spot diameter will not be accurate and may result in over treatment or under treatment if the eyepieces are not properly adjusted.*

*When the system is in READY mode, if the aiming beam is not present, is distorted, or is incomplete, do not proceed with treatment. Turn off the machine and contact service.*

*It is the responsibility of the physician to select appropriate combinations of repetition rate and exposure time to avoid overexposure or unintended exposure.*

*It is the responsibility of the physician to verify that the pattern visualized through the slit lamp is the same as the pattern displayed on the control panel. A discrepancy between patterns could indicate a hardware failure. Should this occur, discontinue treatment and*

contact service.

*Early release of the footswitch will terminate the treatment beam before the complete pattern has been delivered. It is recommended that the pattern be completed by delivering the burns individually. DO NOT repeat the pattern at the same targeted tissue, as the pattern will start from the beginning, resulting in overlapping burns.*

*When a pattern with multiple spots is selected, use caution when operating with a multiple mirror contact lens. Do not overfill the mirror with the pattern and ensure that you have visualization of the complete pattern and the area to be treated prior to laser treatment.*

*Do not use any contact lens with a laser spot magnification of  $<0.94$ .*

*Do not use wide field contact lenses. Wide field lenses will enlarge the spot diameter and alter the Foveal Exclusion Zone ring diameter.*

*Selecting the wrong contact lens or entering the incorrect magnification factor for a custom lens will cause the displayed fluence to be incorrect. Endpoint Management modulates both Power (mW) and Exposure (ms) simultaneously. When Power reaches the lower limit, only Exposure is adjusted. If engaging Endpoint Management at or near these minimum power limits, lower Endpoint Management percentage values may be required.*

*Do not use the LIO if it has been dropped or if there is visible damage to the housing or fiber until the LIO has been checked to work properly by certified personnel.*

*The video monitor must not be used to guide treatment or for diagnosis. The treating physician must visualize treatment through the slit lamp at all times.*

*Footswitch marked with IPx1 is suitable for general or office use. Do not use the system with footswitch in the operating room.*

*When used in a surgical environment, ensure all concentrations of O<sub>2</sub> are low and that flammables or volatile anesthetics, alcohol and surgical preparation solutions are decreased. All solution soaked materials must be separately bagged and contained and/or removed from the room prior to the use of laser (e.g. prepping dispensers, applicators, drip drapes). This includes items used by the anesthesia providers. The anesthesia provider will decrease FIO<sub>2</sub> (Fraction of inspired oxygen) to minimum amount possible to maintain adequate SpO<sub>2</sub>. Be aware of possible enriched O<sub>2</sub> and N<sub>2</sub>O atmospheres near the surgical site under the drapes, especially during head and neck surgery. Tent drapes to allow oxygen, which is slightly heavier than air to drain away from the patient's head and toward the floor.*



## **CAUTION**

*If the system becomes unresponsive at any time other than during laser emission, do not press the emergency laser stop button. Instead, turn the key switch to the OFF position. Wait at least one minute before restarting the system using the key switch.*

*If the control panel is blank for more than 60 seconds during system start-up, verify that the power indicator LED on the front of the control panel is illuminated. If it is not illuminated, then press the Power button on the right of the control panel to turn on the control panel. If the control panel remains blank, turn off the system with the key; verify that all control panel cables are plugged in and fully seated; and then restart the system. If the screen is still blank, turn off the system and contact service.*

---

*It may take longer for the equipment to achieve a ready state in a low-temperature environment.*

*It is the responsibility of the physician to verify that the aiming beam spot visualized through the slit lamp is the expected size. If the aiming beam size or pattern appears inappropriate or distorted, do not proceed with treatment. Readjust the slit lamp focus. If the problem persists, contact service.*

*It is the responsibility of the physician to select the appropriate power and treatment location. The lowest practical setting should always be used to achieve the desired clinical outcome.*

*Do not use a wet cloth to clean the control panel screen. Doing so may damage the screen.*

## Additional Safety Considerations



### WARNING

*US federal law restricts this device to sale by or on order of a physician. (CFR 801.109(b)(1))*

*Use of controls or adjustments or performance of procedures other than those specified herein may result in hazardous radiation exposure.*

*Iridex Corporation medical devices are solely for use by physicians trained in the operation of laser photocoagulation and associated delivery devices.*

*To avoid potential injury to the user and the patient and/or damage to this device, the user must:*

- *Read this manual thoroughly and be familiar with its contents prior to using this equipment.*
- *Be a qualified physician, having complete knowledge of the use of this device.*
- *Test this device prior to a procedure.*
- *Attempt no internal repairs or adjustments not specifically detailed in this manual.*

*Do not modify this equipment without authorization of the manufacturer.*

*When the laser system is interconnected with other medical electrical equipment, leakage currents may be additive. Ensure all systems are installed according to the requirements of IEC 60601-1.*

*If the laser system is used adjacent to or stacked with other equipment, observe and verify normal operation of the laser system in the configuration in which it will be used prior to use.*

*Use of accessories, transducers and cables other than those specified or provided by the manufacturer of this equipment could result in increased electromagnetic emissions or decreased electromagnetic immunity of this equipment and result in improper operation.*

*Portable RF communications equipment (including peripherals such as antenna cables and external antennas) should be used no closer than 30 cm (12 inches) to any part of the laser system, including cables specified by the manufacturer. Otherwise, degradation of the performance of this equipment could result.*



### CAUTION

*Condensation may occur if the equipment is exposed to high humidity for an extended period of time.*

*Vibration or physical shock may affect the quality, performance and reliability of the equipment.*

## **Regulatory Compliance Safety Features**

PASCAL Synthesis Ophthalmic Scanning Laser System complies with 21 CFR subchapter J as administrated by the Center for Devices and Radiological Health of the Food and Drug Administration (FDA). The following FDA compliance safety features are included:

### ***Key Lock Switch***

The system can be activated only with the proper key to operate the master key switch. The key cannot be removed in the ON position and the system will operate only with the key in place. When treatments are complete, always remove and secure the key to prevent unauthorized use of the system.

### ***Laser Emission Indicator***

The laser emission indicator is displayed to warn the user that the system is capable of emitting laser energy and that appropriate precautions should be taken, such as using the appropriate eyewear when in the treatment room.

### ***Door Interlock***

A door interlock may be used in conjunction with a remote switch to disable the system in case of certain external events (e.g., the opening of a treatment room door). A remote switch or interlock can be wired to the door interlock plug and connected to the system interlock receptacle on the rear of the system console. If a remote switch is used, the system can be set in the READY mode only when the remote switch is closed. Breaking the connection by opening the switch (door) or removing the plug disables the system and the system returns to STANDBY mode with “<Door Interlock>” displayed on the control panel.

### ***Emergency Stop***

When pressed, immediately turns off power to the laser.

### ***Protective Housing***

The system console has a protective housing that prevents unintended human access to laser radiation above Class I limits. This housing is to be opened only by certified personnel.

### ***Safety Interlocks***

The protective housing is not designed to be removed by the user during operation or maintenance. Therefore, the system does not have and is not required to have any safety interlock within the meaning of US FDA 21 CFR, Section 1040 or European EN 60825-1.

### ***Safety Shutter***

The laser system utilizes an electronic laser safety shutter. The system will not be able to emit laser light unless all safety conditions are met prior to depressing the footswitch. The safety shutter is activated when the system is off, during the self-test at turn-on, in STANDBY mode or when the safety monitor detects a fault.

### ***Location of Controls***

Controls are located on the touch screen control panel.

### ***Manual Reset***

If laser emission is externally interrupted during treatment by activation of the door interlock, the system will automatically go into STANDBY and the safety shutter will revert to a closed position. To resume treatment, reset the system by placing the laser in READY.

If laser emission is interrupted by main electrical power loss, the system will automatically turn off. To resume treatment after an electrical power loss, the system must first be manually restarted by rotating the key switch to the ON position.

### ***Electrical Fault Detection Circuitry***

If the electronic system detects a fault condition, laser exposure cannot occur. The laser is disabled, the safety shutter is closed and the footswitch is disabled. Some fault conditions may be cleared by the operator. See “Troubleshooting” for additional information.

### ***Location of Regulatory and Other System Labels***

As required by the regulatory bodies, appropriate warning labels have been mounted in specified locations on the instrument to indicate conditions under which the user could be subjected to laser radiation. Location and description of caution, warning and system labels are described on the following pages.

## **Ophthalmic Applications**

PASCAL Synthesis Ophthalmic Scanning Laser System is used to treat ocular diseases in both the posterior and anterior chambers of the eye. The laser systems are well-suited for treating the eye, because they have minimal effect on transparent tissues and materials. PASCAL Synthesis laser energy can be efficiently delivered to opaque structures of the eye through the transparent cornea, aqueous humor, lens and vitreous humor, allowing many conditions to be treated by non-invasive techniques. Laser energy is delivered to opaque structures within the eye through a slit lamp that has been specially adapted for use as a laser delivery system.

The delivery system includes a lens system to focus the laser energy and vary the size of the laser spot in the plane of observation of the slit lamp. It includes a mechanism to manipulate the position of the laser beam without moving the slit lamp. Laser energy is delivered to the slit lamp through a flexible fiber optic.

For most procedures, a laser contact lens is used to direct laser energy to the part of the eye being treated. The contact lens may have mirrors so that laser energy can be delivered to

---

areas of the retina behind the iris or into the angle so that the trabecular meshwork can be treated. The contact lens also helps to hold the eye open and still so that laser energy can be delivered effectively.

Systems may be used for procedures performed in a hospital or in a physician's office, for in-patient or out-patient procedures. The use of the laser system is not a contributing factor in deciding whether a procedure is done on an in- or out-patient basis.

## Contraindications

The following conditions are contraindications for performing laser trabeculoplasty:

- Any corneal opacities, cataract formation and vitreous hemorrhage which can interfere with the laser surgeon's view of the target structures
- Aphakic eye with vitreous in the anterior chamber
- Neovascular glaucoma
- Glaucoma caused by congenital abnormalities of the angle
- Less than 90° of open angle or extensive low-lying peripheral anterior synechiae present circumferentially around the angle
- Significant corneal edema or a diminished aqueous clarity obscuring visualization of the angle detail
- Glaucoma secondary to active uveitis

Tissue absorption is directly dependent upon presence of pigmentation; therefore, dark pigmented eyes will require lower energies to obtain equivalent results as compared to light pigmented eyes. Do not treat albino patients that have no pigmentation.

For patients with wide variations in retinal pigmentation as evaluated by ophthalmoscopic observation, select multi-spot patterns which cover a homogeneously pigmented smaller area to avoid unpredictable tissue damage.

Exercise caution while setting treatment parameters (for example exposure time and the number of spots per pattern) when laser burns are to be delivered in the non-macular area for long time periods leading to longer grid completion times. Please be aware that with longer completion times, the possibility of patient movement increases the risk of treatment of unintended targets.

In addition, following are the contraindications for photocoagulation treatment:

- Patient cannot fixate their eye or hold still (for example patient has nystagmus).
- There is inadequate view of the fundus due to opacity (not clear media so physician cannot see the fundus).
- Presence of sub retinal fluid in the patient's eye.

## Potential Complications or Side Effects

Potential complications specific to retinal photocoagulation include inadvertent foveal burns, choroidal neovascularization, paracentral scotomata, subretinal fibrosis, photocoagulation scar expansion, Bruch's membrane rupture, choroidal detachment, exudative retinal detachment, pupillary abnormalities from damage to the ciliary nerves, and optic neuritis from treatment directly or adjacent to the disc.

Potential complications specific to laser iridotomy include iritis, visual symptoms, and rarely, retinal detachment.

## Adverse Effects and Complications

### Posterior Segment Laser Procedures



#### WARNING

*The most common complication of panretinal photocoagulation is increased macular edema usually with a concurrent decrease in visual acuity. In addition, blowout hemorrhages from the areas of neovascularization, particularly on the optic nerve, have been observed and may be caused by an increase in peripheral resistance secondary to photocoagulation or by an inadvertent valsalva maneuver by the patient.*

*Only a contact lens specifically designed for use with laser energy should be used. Use of a standard diagnostic contact lens may result in a power loss due to reflection from the surface of the lens. The reflected energy may pose a hazard to both the patient and the physician.*



#### WARNING

*Following photocoagulation, patients should be cautioned against any activity that could increase the venous pressure in the head, neck or eyes, such as straining, lifting or holding their breath. Patients should be advised to sleep with the head of their bed elevated 15 to 20 degrees.*

*Patients should be cautioned against stifling a sneeze, because this raises the blood pressure within the eyes to a high level. Vigorous nose blowing should also be discouraged. Rubbing the eyes following photocoagulation may disrupt blood vessels inside the eyes. Sneezing and coughing should be controlled with cough syrup or other medications.*

*Immediately following treatment, patients should avoid altitudes over 2500 m (~8000 ft.).*

### Anterior Segment Laser Procedures



#### WARNING

*Intraocular pressure should be closely monitored following laser iridotomy or trabeculoplasty.*

*Hemorrhage from the trabecular meshwork occasionally occurs as an ooze of blood from Schlemm's canal to the site of laser impact. This is easily stopped by increasing the pressure on the gonio lens on the cornea or by coagulating the bleeding site by application of a laser burn.*

*Pupillary distortion may be encountered if the iris root or peripheral iris has been treated. This distortion may or may not be permanent, depending on the severity of the accidental*

damage.



## **WARNING**

*Intraocular pressure elevations have been reported to occur in up to 53% of eyes when 360° of the trabecular meshwork has been treated with 100 spots at the initial session. Intraocular pressure rises occur most frequently from 1 to 2 hours following laser treatment, although they may occur several hours afterward. For this reason, it is imperative to monitor patient intraocular pressure after laser treatment for up to 24 hours.*

*Peripheral anterior synechiae may occur when the posterior portion of the trabecular meshwork or other structures posterior to the meshwork are treated. These are best avoided by meticulous delivery of a well-focused laser beam.*

*Transient corneal epithelial burns have reportedly been resolved within 1 week without scarring. Endothelial burns are rarely encountered when careful focusing is employed.*

*Rarely, severe iritis may occur, related to either an unusual patient response or improper spot location.*

## System Components

### *Laser Console*

Houses the key switch, emergency laser stop button, fiber ports, laser fiber and electronics cable, 532 nm or 577 nm single wavelength laser, control electronics and power supply.



### *Touchscreen LCD Control Panel*

Provides controls for selecting treatment parameters and displays for monitoring system information.



## **Slit Lamp (model SL-PA04)**

Integrated slit lamp connection. Service personnel will connect laser system to slit lamp.

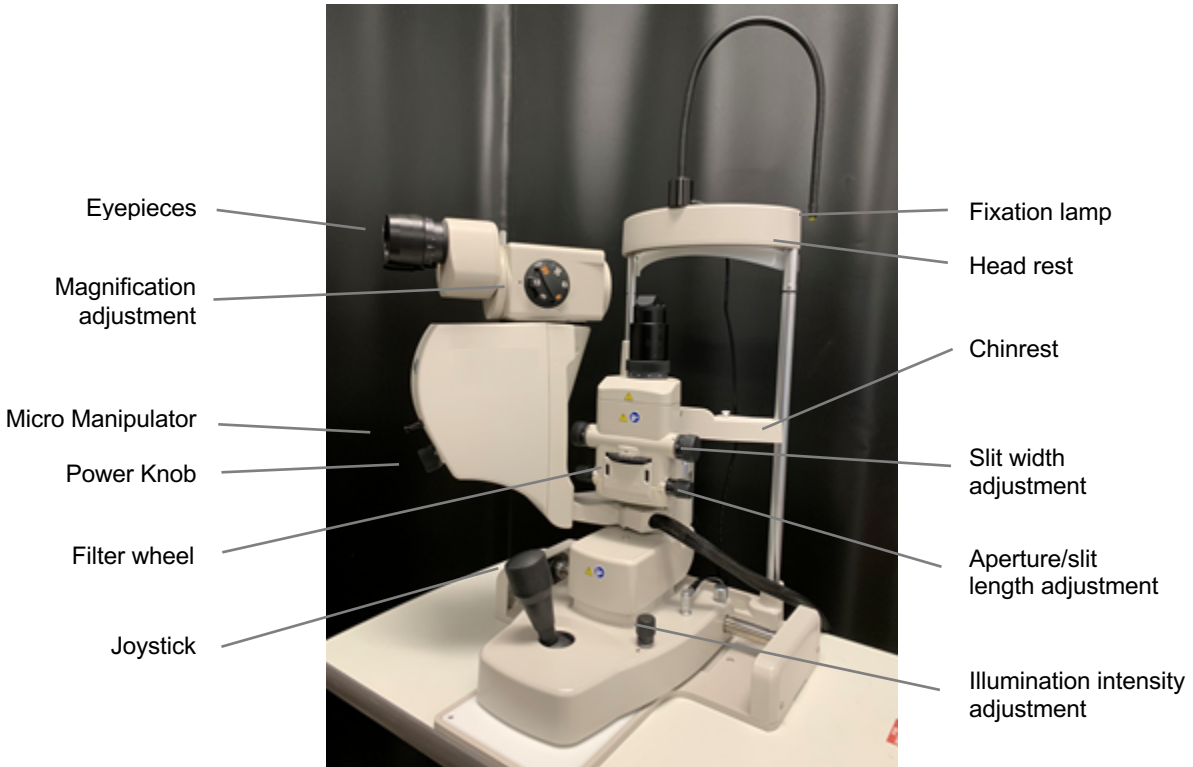

*PASCAL Synthesis Slit Lamp PA04*

### **Footswitch**

Activates laser treatment beam when depressed while system is in READY mode.



### **NOTE**

*Footswitch marked with IPX1 is suitable for general or office use.*

### **Door Interlock Plug**

Disables laser if treatment room doors are opened or interlock plug is removed. Use is optional; however, interlock plug must be inserted for laser to operate.

## ***Micro Manipulator***

Provides auxiliary input for laser position. The aiming beam/treatment beam can be moved up/down/left/right in same direction as the micro manipulator (MM) moves. The movement is centered around any position offset (if any) introduced by the 3D controller.

The micro manipulator will return to mechanical center when released. There maybe a few counts from true center after released the Micro Manipulator, the user can press Home button to make it center.



### **NOTE**

- *The Micro Manipulator is disabled during the laser treatment*

## ***Power Knob***

The Power Knob located below the Micro Manipulator provides auxiliary input for laser power.

User can adjust power up or down by rotating the power knob similar to the touch screen power up or down. Clockwise rotation increases the power and Counter clockwise rotation decreases the power.



### **NOTE**

- *The Power Knob is disabled during the laser treatment*

### 3D Controller (Purchased Separately)

Provides auxiliary input for laser position and parameters. Parameters are adjusted by motion of controller.

#### 3D Controller Action

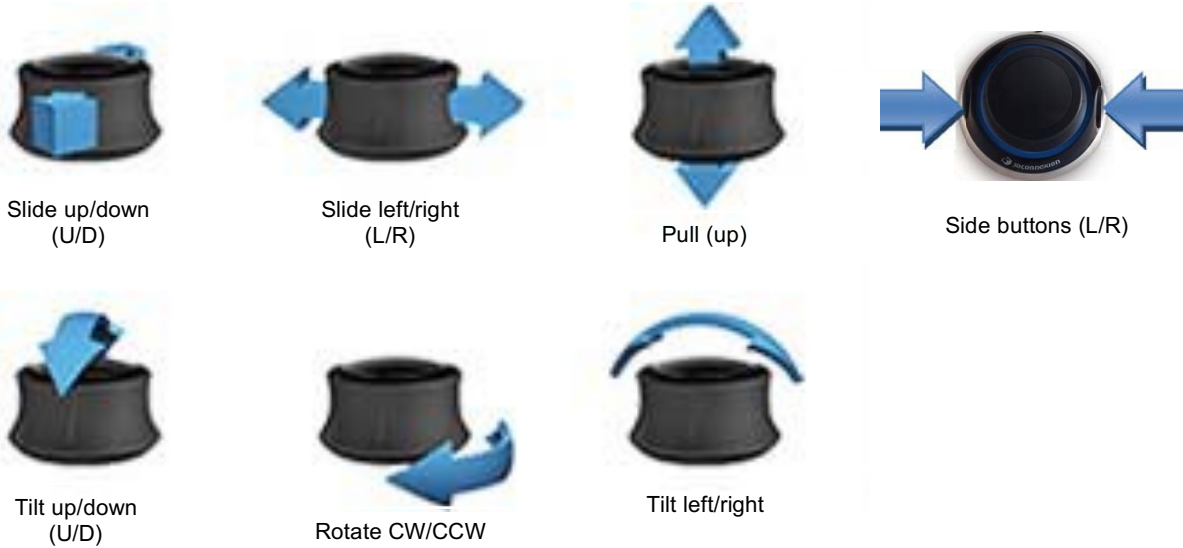

#### 3D Controller Configurations

Function	Action	Default	Advanced	Power
Micromanipulator	Tilt (U/D/L/R)	✓	✓*	--
Titrate / Center	Pull	✓	✓	--
Spots	Slide U/D	--	✓**	--
Spacing	Slide L/R	--	✓**	--
Orientation	Rotate CW/CCW	--	✓**	--
Power Increase	Right side button	✓	✓	✓
Power Decrease	Left side button	✓	✓	✓
			* Single Spot only	
			** Full Pattern Only	

***LIO (Laser Indirect Ophthalmoscope) – optional accessory***

The LIO is an optional accessory to the PASCAL systems. Refer to the LIO operator manual for detailed safety and regulatory compliance information.



## System Installation and Setup

PASCAL Synthesis Ophthalmic Scanning Laser System is designed for installation and use in a darkened office or surgery room. Optimal system performance and viewing is achieved in low ambient light conditions. PASCAL Synthesis system installation and testing will be performed at your facility by Iridex Corporation-certified personnel.

PASCAL Synthesis Ophthalmic Scanning Laser System is equipped with a 3-wire Hospital Grade AC power cord. When selecting the location for system installation, ensure that the AC wall power outlet is correctly grounded. Follow local electrical codes to ensure proper grounding of the AC wall power outlet. A correctly grounded power connection is required for safe system operation.



### NOTE

*Do not position the laser system to make it difficult to operate the disconnection device.*

Select an appropriate location that can accommodate the system size and allow for easy access by both the patient and the physician. Ensure proper ventilation, temperature and relative humidity. Select a well-ventilated space in an office or surgery room. Refer to **Environmental Requirements (Operational)** and ensure the location of installation meets the temperature and relative humidity requirements listed. Position the system to aim the treatment beam away from windows and doors. Post a laser safety sign at the entrance to the treatment room.

Do not block cooling airflow or cooling vents on the laser system. Allow at least 5 cm (2 in) of clear space around the laser system to provide adequate system cooling airflow. Use care when routing system cables to prevent a tripping hazard and to protect the optical fiber from damage by being crushed under foot or being rolled over by a chair. If the cord must cross a floor where there is traffic, use of a floor cord/cable cover is recommended.

## Connecting the System Components

Refer to the following diagrams for the location of system component connections on the front and rear panels of the console.

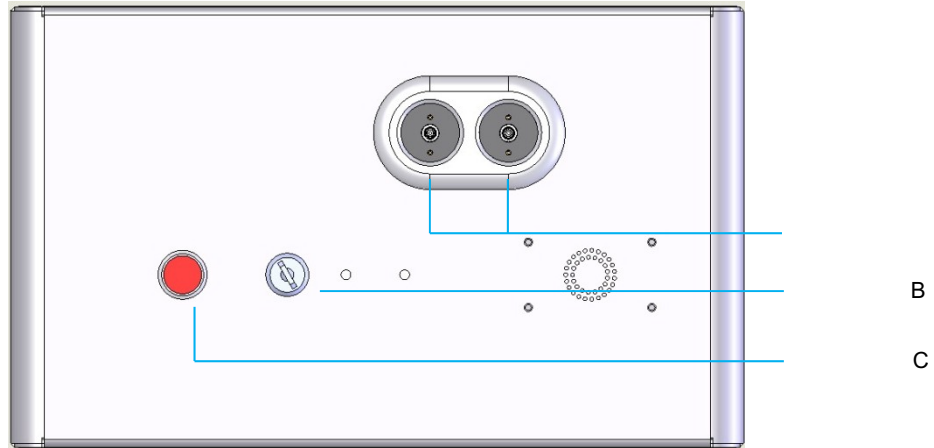

*Front Panel Connections*

<b>A</b>	Fiber ports—for connection to LIO
<b>B</b>	Key switch
<b>C</b>	Emergency Stop

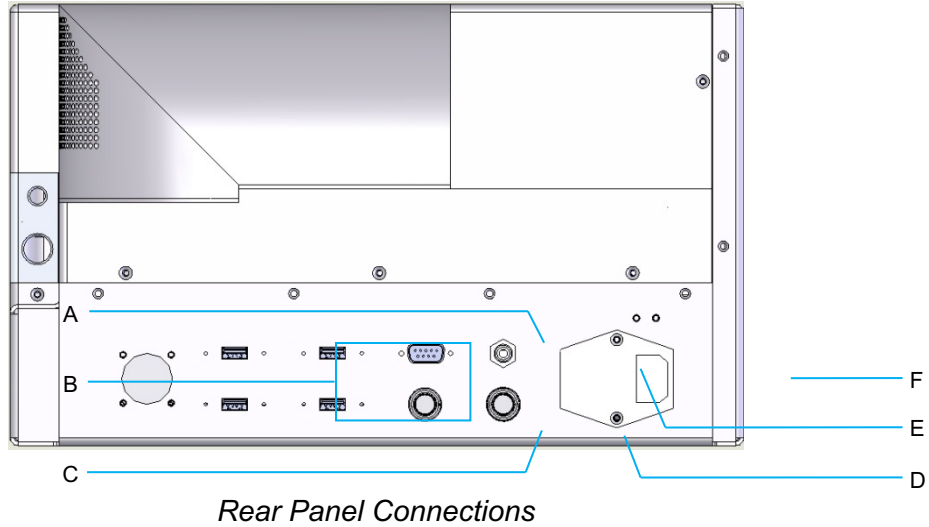

<b>A</b>	LCD control panel receptacle
<b>B</b>	USB ports—3D Controller, and touch screen monitor
<b>C</b>	Monitor power receptacle
<b>D</b>	Footswitch receptacle
<b>E</b>	Door interlock receptacle—must be inserted for laser to operate
<b>F</b>	Main power cable receptacle



### NOTE

*If using an external door interlock, a qualified electrical professional must install the external switch, and the total length of the cable should not exceed 5 m (16 ft.).*



### CAUTION

USB Ports are not compatible with wireless devices. Use of the USB Ports with a wireless device cannot guarantee the performance of the wireless device or the Pascal Synthesis System.

## System Start-up and Shut-down

### *Starting the System*

1. Connect system to a wall power outlet.
2. Insert key into key switch.
3. Turn key switch to ON position.



*Key Switch*

### *Shutting Down the System (Standard Shut-down)*

From the Treatment screen:

4. Place system in STANDBY mode.
5. Press <End Treatment> to return to the <Home Screen>.

From the Home screen:

6. Turn key switch to OFF position.
7. Remove key to prevent unauthorized use of system.



#### **NOTE**

*If the power cable is still connected to the electrical source, some internal circuits remain energized. To de-energize all internal circuits, turn the key switch to the OFF position and unplug the power cable from the wall.*

### *Emergency Shut-down*

If the system becomes unresponsive during laser emission, press the emergency laser stop button on the front of the console. Turn the key switch to the OFF position.

Before restarting, press the emergency laser stop button to disengage it.

# Control Screen Description

## Home Screen

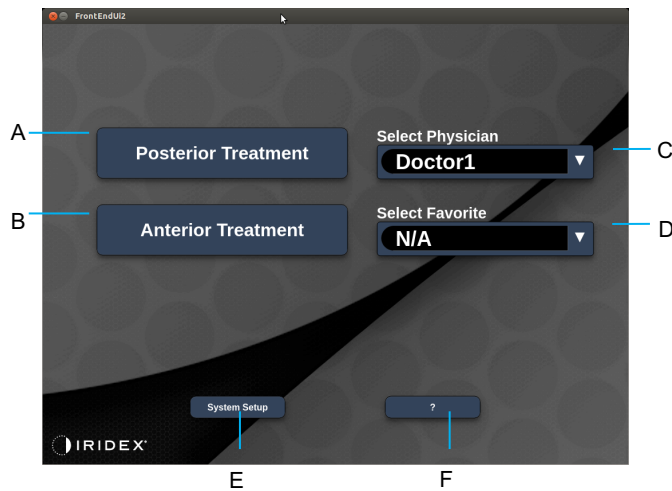

<b>A</b>	<Posterior Treatment> - press <b>Posterior Treatment</b> button and go to Treatment Screen
<b>B</b>	<Anterior Treatment> - press <b>Anterior Treatment</b> button and go to Treatment Screen
<b>C</b>	<Select Physician> - press to display physicians
<b>D</b>	<Select Favorites> - press to display favorite settings
<b>E</b>	<System Setup> - press configure system
<b>F</b>	<?> - press to go to system software version dialog

## Posterior Treatment Screen

Press <Posterior Treatment> button on the Home Screen to access the Posterior Treatment Screen.

The system will display warming up message at the center of the treatment screen during system warm up.





Style 1.0

<b>A</b>	Status - press to select system status (STANDBY or READY mode)
<b>B</b>	<Counter> - displays number of applications during treatment <Σn=0> - press to reset counter (Enable in preferences)
<b>C</b>	Information - displays optional information and warning messages
<b>D</b>	<Favorites> - press to open <Favorites> window, see the section “Favorites Window”
<b>E</b>	<LENS> - press to open <Contact Lens> menu
<b>F</b>	<END> - press to end treatment
<b>G</b>	<Output> - displays laser output value <Δ> - press to toggle units
<b>H</b>	<PORT 1 or 2> - press to select output device (only Style 1.0 available)



Style 1.0

<b>A</b>	<Power> - press up/down buttons to adjust
<b>B</b>	<Exposure> - press up/down buttons to adjust
<b>C</b>	<Endpoint Mgmt> - press up/down buttons to adjust ( <i>EpM feature is available when activated</i> )
<b>D</b>	<EpM> - press to enable/disable Endpoint Management <LM> - press to toggle Landmark patterns
<b>E</b>	<Rep Rate/Curve/Radius> - press up/down buttons to adjust
<b>F</b>	<IN> - press to adjust inner radius <OUT> - press to adjust outer radius

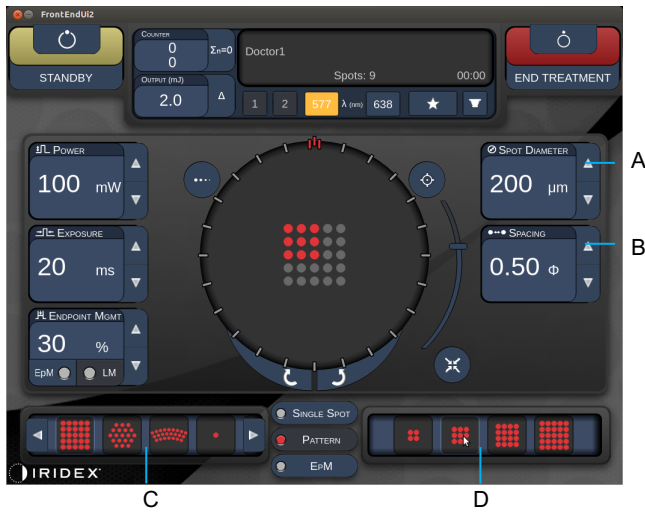

Style 1.0

<b>A</b>	<Spot Diameter> - press up/down buttons to adjust
<b>B</b>	<Spacing> - press up/down buttons to adjust
<b>C</b>	Primary Pattern - press to select pattern type
<b>D</b>	Secondary Pattern - press to select pattern subset (when applicable)



## NOTE

- *Parameter controls only show on screens when applicable to the pattern selected.*
- *Establish treatment parameters with Enhanced Octant when in “Standby” mode. The Enhanced Octant pattern will increase the number of “spots” to accompany changes in geometry (spot diameter, spacing, radii). Changes to geometry are only possible when system is in “Standby” mode. Once in “Treat” mode, after the first laser application is applied, only changes to Power, Exposure and Endpoint are allowed.*

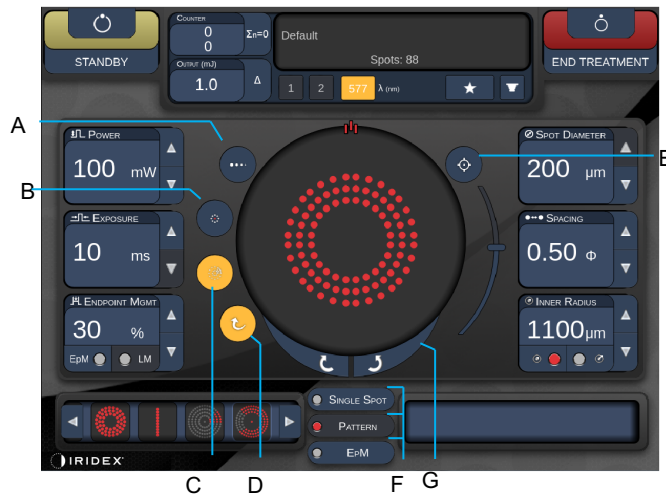

Style 1.0

<b>A</b>	<Titrate> - press to switch to single spot to perform test burns, adjustable up to 4 spots; press again to revert to prior laser mode
<b>B</b>	<Fixation> - press to turn on fixation light (when applicable)
<b>C</b>	<Outline> - press to enable full pattern outline (when applicable)
<b>D</b>	<Auto> - press to enable automatic advancement (when applicable)
<b>E</b>	<AIM> - press to turn on/off aiming beam in STANDBY (always on in READY) Aiming beam intensity - scroll up/down to adjust
<b>F</b>	<Single Spot>/<Pattern>/<EpM> - press to display patterns available at default parameter setting
<b>G</b>	<Rotate> - press to rotate or advance pattern (when applicable)
<b>H</b>	<Center> - press to position the beam to optical center of the treatment



## NOTE

- *Parameter controls only show on screens when applicable to the pattern selected. See the section “Pattern Descriptions/Pattern Parameters” for detailed information.*
- *Center Button requires the micro manipulator is not being used*

## Anterior Treatment Screen

Press < Anterior Treatment> button on the Home Screen to access the Anterior Treatment Screen. The system may also display warming up message at the center of the treatment screen during system warm up (see the section “Posterior Treatment Screen”).

The Anterior Treatment screen is identical to the Posterior Treatment screen, except that the only available patterns are the PSLT 3 row, Array and Single Spot patterns.

The Endpoint Management feature is not available.

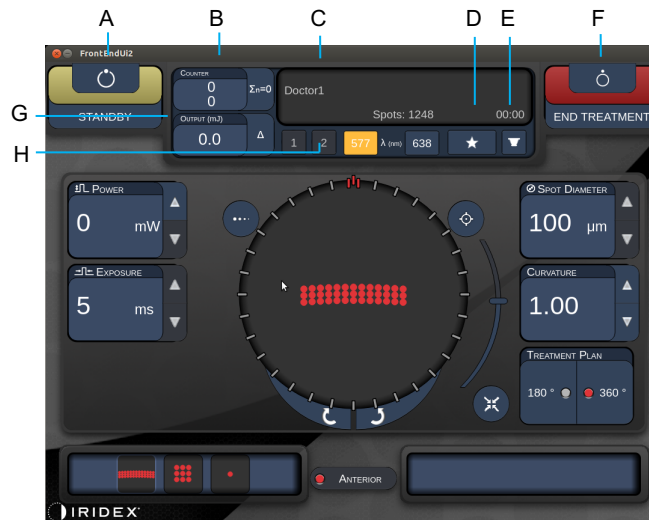

Style 1.0

<b>A</b>	Status - press to select system status (STANDBY or READY mode)
<b>B</b>	<Counter> - displays number of applications during treatment <Σn=0> - press to reset counter (Enable in preferences)
<b>C</b>	Information - displays optional information and warning messages
<b>D</b>	<Favorites> - press to open <Favorites> window
<b>E</b>	<LENS> - press to open <Contact Lens> menu
<b>F</b>	<END > - press to end treatment
<b>G</b>	<Output> - displays laser output value <Δ> - press to toggle units
<b>H</b>	<PORT 1 or 2> - press to select output device (Only Style 1.0 available)



Style 1.0

<b>A</b>	<Titrate> - press to switch to single spot to perform test burns, adjustable up to 4 spots; press again to revert to prior laser mode
<b>B</b>	<Power> - press up/down buttons to adjust
<b>C</b>	<Exposure> - press up/down buttons to adjust
<b>D</b>	Primary Pattern - press to select pattern type
<b>E</b>	<Treatment Plan> - press to toggle between 180° /360° (when applicable)
<b>F</b>	<Rotate> - press to rotate or advance pattern (when applicable)
<b>G</b>	Secondary Pattern - press to select pattern subset (when applicable)
<b>H</b>	<Center> - press to position the beam to optical center of the treatment



## NOTE

- *Center Button requires the micro manipulator is not being used*



Style 1.0

<b>A</b>	<AIM> - press to turn on/off aiming beam in STANDBY
<b>B</b>	<Spot Diameter> - press up/down buttons to adjust
<b>C</b>	<Spacing/Curvature> - press up/down buttons to adjust (when Applicable)
<b>D</b>	<Rep Rate> - press up/down buttons to adjust (when Applicable)













## NOTE

- Parameter controls only show on screens when applicable to the pattern selected. See the section “Pattern Descriptions/Pattern Parameters” for detailed information.

## Posterior Pattern Descriptions/Pattern Parameters

There are three groups, fifteen posterior pattern types in total. The choice of pattern determines which parameters (e.g., radius, curvature, repetition rate, etc.) display on the touchscreen control panel, as well as the range of values for each parameter on the treatment screen.

		<b>Primary Pattern</b>			
<b>Single Spot</b>					
<b>Pattern</b>	<b>20ms Default</b>				
	<b>10ms Default</b>				
<b>EpM</b>					



### NOTE

- When user selects different group among Single Spot, Pattern and EpM, the setting for each parameter for the pattern will be reset to the default.
- When user selects a different pattern within the same group, the setting for each parameter will keep the same unless the value is not within the range for the selected pattern. In that case, the setting will be reset to the default.

## Single Spot

	Primary pattern	Secondary pattern
Single Spot		Not available

## General Use

- PRP, retina tears, retina detachments, iridotomy, trabeculoplasty, LIO

Pattern	Spot Diameter	Repetition Rate	EPM %
Single Spot	50µm	Off, 1.0Hz to 8.0Hz	10 to 95
	100µm		
	200µm		
	400µm		

The Single Spot pattern can be used with the slit lamp or an optional laser indirect ophthalmoscope (LIO). Spot diameter and repetition rate settings are adjustable.



## NOTE

- *The full range of settings is not available for every combination of parameters.*

## Endpoint Management Features

Endpoint Management Off or Disabled	Endpoint Management On/ Landmark On	Endpoint Management On/ Landmark Off
Single-full-power spots (red-100%) 	Single full-power spots (red-100%) 	Single endpoint spots (orange-xx %) 



## NOTE

- *The Endpoint Management feature is not available with the LIO.*

## Array

	Primary pattern	Secondary pattern
20ms Array		

### General Use

- PRP, retina tears and retina detachments

Pattern	Spot Diameter ( $\mu\text{m}$ )	Spacing	EPM %
20 ms Array	50 (2x2 or smaller)	0.00 $\emptyset$ to 3.00 $\emptyset$	10 to 95
	100		
	200		
	400	0.00 $\emptyset$ to 1.50 $\emptyset$	

The 20 ms Array pattern is selectable in a variety of shapes and sizes up to a maximum of 25 spots, including rectangle arrays (e.g., 2x3, 4x2, etc.), square arrays (e.g., 2x2, 3x3, etc.), vertical and horizontal lines of up to five spots. Spot diameter and spacing settings are also adjustable.

To select the Array pattern shape and size, drag your finger horizontally, vertically, or diagonally across the pattern, or press one of the quick-select buttons at the bottom of the Array pattern screen.



### NOTE

- Do not allow to swipe to single spot for all array patterns. If needed, please select the single spot pattern.

## Endpoint Management Features

Pattern Type	Endpoint Management Off or Disabled	Endpoint Management On/ Landmark On	Endpoint Management On/ Landmark Off
1x2, 2x1, 2x2	All full-power spots (red-100%) 	All full-power spots (red-100%) 	All endpoint spots (orange-xx %) 
Single-column or single row arrays with at least 3 spots	All full-power spots (red-100%) 	Two full-power spots (red-100%); remaining endpoint spots (orange-xx %) 	All endpoint spots (orange-xx %) 
All other arrays	All full-power spots (red-100%) 	Four full-power spots (red- 100%); remaining endpoint spots (orange-xx %) 	All endpoint spots (orange-xx %) 

## Hexagon

	Primary pattern	Secondary pattern
20ms Hexagon		

### General Use

- PRP, retina tears and retina detachments

Pattern	Spot Diameter (µm)	# of Spots	Spacing	EPM %
20 ms Hexagon	100	7, 19 and 37	0.00Ø to 3.00Ø	10 to 95
		200	7, 19	
	400		37	
		7	0.00Ø to 3.00Ø	
			19	
	37	0.00Ø to 0.50Ø		

The 20 ms Hexagon pattern is selectable in three sizes and twenty-four orientations. Spot diameter and spacing settings are also adjustable.

To select the Hexagon pattern orientation, press one of the tickmarks on the rotation guide that displays in the pattern background. The tickmarks are positioned at 15 degree intervals, from 0 to 345 degrees.



### NOTE

- *The selection of spacing will differ depending on slit lamp used.*

## Endpoint Management Features

# of Spots	Endpoint Management Off or Disabled	Endpoint Management On/ Landmark On	Endpoint Management On/ Landmark Off
7	All full-power spots (red-100%) 	Six full-power spots (red-100%); remaining endpoint spots (orange-xx %) 	All endpoint spots (orange-xx %) 
19			
37			

## Triple Arc

	Primary pattern	Secondary pattern
20ms Triple Arc		Not available

## General Use

- PRP, retina tears, retina detachments

Pattern	Exposure Time (ms)	Spot Diameter ( $\mu\text{m}$ )	Spacing	Curvature	EPM %
20 ms Triple Arc	15 to 30	200	0.25 $\emptyset$ to 3.00 $\emptyset$	0.00 to 2.00	10 to 95
		400	0.25 $\emptyset$ to 1.50 $\emptyset$		

The Triple Arc pattern is selectable in various orientations, depending on the spot diameter, spacing, and curvature settings. You must select the spot diameter, spacing, and curvature settings before selecting the pattern orientation. If you select the pattern orientation and then select the spot diameter, spacing, and/or curvature settings, the pattern returns to its default orientation.

To select the pattern orientation, drag your finger along the outside of the rotation guide that displays in the pattern background.

## Auto Advance Feature



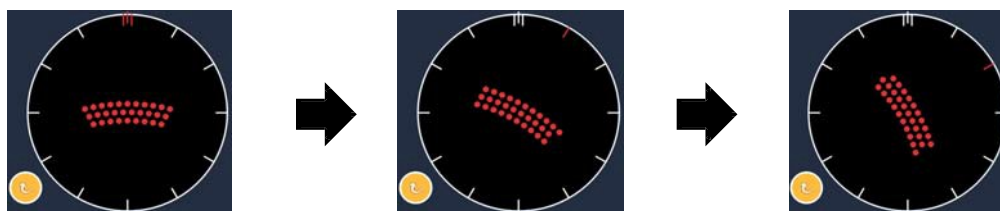

If the Auto Advance feature is enabled, the first Triple Arc pattern is delivered when you depress the footswitch, after which the system automatically rotates the pattern at 30 degree intervals. When you press the footswitch a second time, the pattern is delivered, and the system automatically rotates pattern.

The orientation is selectable in clockwise and counter-clockwise on the Physician Preferences.

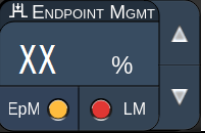
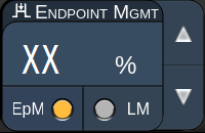

*System Automatically Advances to Next Pattern when Auto Advance Feature is Enabled*

## Endpoint Management Features

Pattern Type	Endpoint Management Off or Disabled	Endpoint Management On/ Landmark On	Endpoint Management On/ Landmark Off
			
Triple Arc	<p>All full-power spots (red- 100%)</p> <p>Example:</p> 	<p>Four full-power spots (red- 100%); remaining endpoint spots (orange-xx %)</p> <p>Example:</p> 	<p>All endpoint spots (orange-xx %)</p> <p>Example:</p> 

**Single Spot**

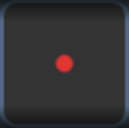
	Primary pattern	Secondary pattern
<b>20ms Single Spot</b>		Not available

See the section “Posterior Pattern Description/Pattern Parameters” for the detailed information on the Single Spot pattern.

## Wedge

	Primary pattern	Secondary pattern
20ms Wedge		

## General Use

- PRP, retina tears, retina detachments

Pattern	Exposure Time (ms)	Spot Diameter (µm)	Spacing	EPM %
20 ms Wedge	15 to 30	100	0.00Ø to 3.00Ø	10 to 95
		200	0.00Ø to 2.00Ø	
		400	0.00Ø to 1.00Ø	

The Wedge pattern is selectable in four sizes and twenty-four orientations. Spot diameter and spacing settings are also adjustable.

To select the Wedge pattern size, press one of the quick-select buttons at the bottom of the Wedge pattern screen. To select the pattern orientation, press one of the tickmarks on the rotation guide that displays in the pattern background. The tickmarks are positioned at 15 degree intervals, from 0 to 345 degrees.

## Endpoint Management Features

Pattern Type	Endpoint Management Off or Disabled	Endpoint Management On/ Landmark On	Endpoint Management On/ Landmark Off
Wedge	<p>All full-power spots (red-100%)</p>	<p>Three full-power spots (red- 100%); remaining endpoint spots (orange-xx %)</p>	<p>All endpoint spots (orange-xx %)</p>

## Arc

	Primary pattern	Secondary pattern
20ms Arc		

### General Use

- PRP, retina tears, retina detachments

Pattern	Spot Diameter ( $\mu\text{m}$ )	Spacing	Radius (Inner ring)
20 ms Arc	200	0.00 $\emptyset$	500 $\mu\text{m}$ to 1400 $\mu\text{m}$
		0.25 $\emptyset$	500 $\mu\text{m}$ to 1600 $\mu\text{m}$
		0.50 $\emptyset$	500 $\mu\text{m}$ to 1900 $\mu\text{m}$
20 ms Arc with Auto Advance	200	0.00 $\emptyset$ to 0.50 $\emptyset$	500 $\mu\text{m}$ to 2000 $\mu\text{m}$
		0.00 $\emptyset$	500 $\mu\text{m}$ to 1000 $\mu\text{m}$
		0.25 $\emptyset$	500 $\mu\text{m}$ to 1200 $\mu\text{m}$
		0.50 $\emptyset$	500 $\mu\text{m}$ to 1500 $\mu\text{m}$

The Arc pattern is selectable in various shapes and sizes, including a single spot, a full circle, and arcs of any number of spots in between. Spot diameter, spacing, and radius settings are also adjustable.

To select the Arc pattern shape and size, drag your finger around the Arc pattern, or press the secondary pattern button at the bottom of the Arc pattern screen to select a full circle.

### Auto Advance Feature

If the Auto Advance feature is enabled, the inner ring pattern is delivered when you depress the footswitch, after which the system automatically advances to the middle ring. When you press the footswitch a second time, the middle ring pattern is delivered, and the system advances to the outer ring. Press the footswitch a third time to deliver the outer ring pattern. After the outer ring pattern is delivered, the system returns to the inner ring.



*System Automatically Advances to Next Ring when Auto Advance Feature is Enabled*



### NOTE

- *If the Auto Advance feature is disabled, only the inner ring displays on the Arc pattern screen.*
- *The Endpoint Management feature is not available for Arc pattern.*

## Triple Ring

	Primary pattern	Secondary pattern
20ms Triple Ring		Not available

### General Use

- PRP, retina tears, retina detachments

Pattern	Spot Diameter ( $\mu\text{m}$ )	Spacing	Radius (Inner ring)
20 ms Triple Ring	200	0.50 $\emptyset$	500 $\mu\text{m}$
	400	0.00 $\emptyset$	500 $\mu\text{m}$ to 600 $\mu\text{m}$
		0.25 $\emptyset$	500 $\mu\text{m}$ to 700 $\mu\text{m}$
		0.50 $\emptyset$	500 $\mu\text{m}$ to 1000 $\mu\text{m}$

The Triple Ring pattern is fixed, but the spot diameter, spacing, and radius settings are adjustable. The entire pattern is delivered when you press the footswitch.



### NOTE

- *The full range of settings is not available for every combination of parameters.*
- *The Endpoint Management feature is not available for Three Ring pattern.*

## Line

	Primary pattern	Secondary pattern
20ms Line		Not available

## General Use

- PRP, retina tears, retina detachments, focal laser

Pattern	Spot Diameter ( $\mu\text{m}$ )	Spacing	EPM %
20 ms Line	100	0.00 $\emptyset$ to 3.00 $\emptyset$	10 to 95
	200		
	400		

The Line pattern is selectable in nine sizes (2 to 10 spots) and twenty-four orientations. Spot diameter and spacing settings are also adjustable.

To select the Line pattern size, drag your finger up or down the Line pattern. Dragging from top to bottom increases the number of spots; dragging from bottom to top decreases the number of spots.

To select the pattern orientation, press <Rotate> button at the bottom.

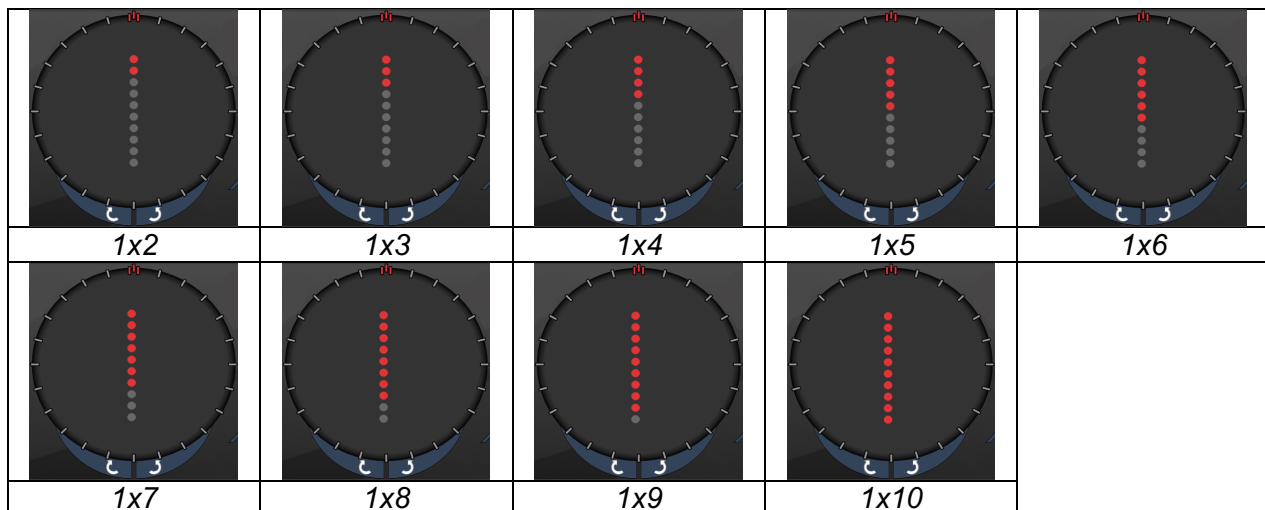

## NOTE

- *The full range of settings is not available for every combination of parameters.*
- *Do not allow to swipe to single spot for line patterns. If needed, please select the single spot pattern.*

## Endpoint Management Features

Pattern Type	Endpoint Management Off or Disabled	Endpoint Management On/ Landmark On	Endpoint Management On/ Landmark Off
1x2 lines	<p>All full-power spots (red-100%)</p> <p>Examples:</p>	<p>All full-power spots (red-100%);</p> <p>Examples:</p>	<p>All endpoint spots (orange-xx %)</p> <p>Examples:</p>
Other lines	<p>All full-power spots (red-100%)</p> <p>Examples:</p>	<p>Two full-power spots (red-100%); remaining endpoint spots (orange-xx %)</p> <p>Examples:</p>	<p>All endpoint spots (orange-xx %)</p> <p>Examples:</p>

## Octants

	Primary pattern	Secondary pattern
10ms Octants		

## General Use

Pattern	Spot Diameter	Spacing	Radius (Inner ring)	EPM %
10 ms Octants	100µm	0.25Ø	1100µm to 1600µm	15 to 95 (Exposure 10ms)
		0.50Ø	1100µm to 1500µm	
		1.00Ø	1100µm to 1400µm	10 to 95 (Exposure 15ms)
		1.50Ø	1100µm to 1200µm	
		2.00Ø	1100µm	
	200µm	0.25Ø	1100µm to 1200µm	
		0.50Ø	1100µm	

The Octants pattern is selectable in three formats: **A**, **B**, and **A+B**, as described above. The pattern is selectable in subsets of one to eight octants for A and B formats and one to four octants for the A+B format. Spot diameter, spacing, and radius settings are also adjustable.

To select the Octants pattern format, press the **A**, **B**, or **A+B** button at the secondary of the Octants pattern screen. To select a number of octants, drag your finger around the Octants pattern.

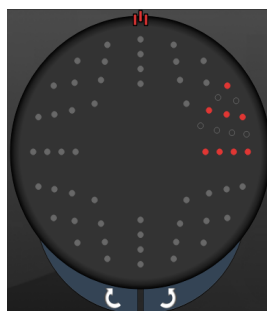

**A**

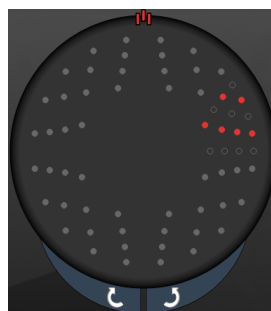

**B**

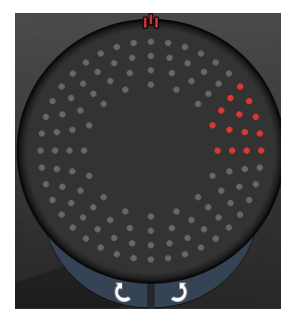

**A+B**

## Auto Advance Feature

The Auto Advance Feature is available only for the A+B format. If the Auto Advance feature is enabled, the selected pattern is delivered when you press the footswitch, after which the system automatically advances to the next pattern.

The orientation is selectable in clockwise and counter-clockwise on the Physician Preferences.

For example, if octants 1 and 2 are selected, the system delivers octants 1 and 2 when you press the footswitch, and then it automatically advances to octants 3 and 4. When you press the footswitch again, the system delivers octants 3 and 4, and then automatically advances to octants 5 and 6, and so on.

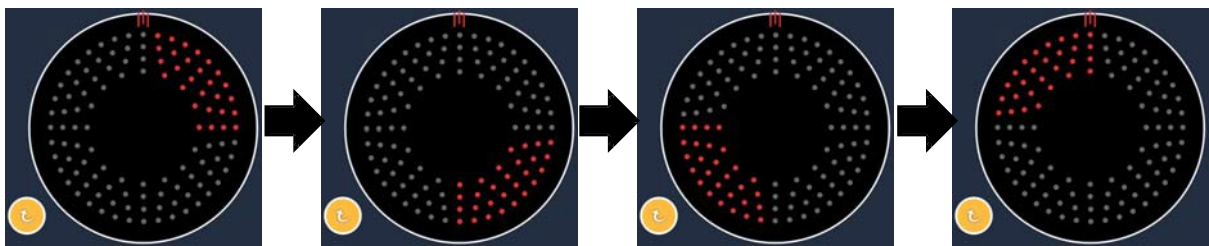

*System Automatically Advances Pattern Clockwise when Auto Advance Feature is Enabled*

## Endpoint Management Features

Pattern Type	Endpoint Management Off or Disabled	Endpoint Management On/ Landmark On	Endpoint Management On/ Landmark Off
Format A+B	All full-power spots (red-100%)	Two full-power spots (red-100%) per octant; remaining endpoint spots (orange-xx %)	All endpoint spots (orange-xx %)
Format A	All full-power spots (red-100%)	Zero, one or Two full-power spots (i.e., only those spots that overlap with format A+B)(red-100%); remaining endpoint spots (orange-xx %)	All endpoint spots (orange-xx %)
Format B	All full-power spots (red-100%)	Zero, one or Two full-power spots (i.e., only those spots that overlap with format A+B)(red-100%); remaining endpoint spots (orange-xx %)	All endpoint spots (orange-xx %)

### Enhanced Octants

	Primary pattern	Secondary pattern
10ms New PC Octants (Enhanced Octants)		Not available

### General Use

Pattern	Spot Diameter	Spacing	Radius (Inner radius)	Radius (Outer radius)	EPM %
Enhanced Octants	100µm	0.00Ø	500µm to 2000µm	700µm to 2200µm	10 to 95
		0.25Ø to 1.00Ø	500µm to 1900µm	800µm to 2200µm	
		1.50Ø to 2.00Ø	500µm to 1800µm	900µm to 2200µm	
		2.50Ø to 3.00Ø	500µm to 1700µm	1000µm to 2200µm	
	200µm	0.00Ø	500µm to 1800µm	900µm to 2200µm	
		0.25Ø to 0.50Ø	500µm to 1700µm	1000µm to 2200µm	
		1.00Ø	500µm to 1600µm	1100µm to 2200µm	

To select a number of octants, drag your finger around the Octants pattern.



### NOTE

- The selection of inner radius and outer radius will differ depending on slit lamp used.
- The full range of settings is not available for every combination of parameters.

### Auto Advance Feature

If the Auto Advance feature is enabled, one segment of Octants pattern is delivered when you depress the footswitch, after which the system automatically advances to the next segment of Octants pattern selected. After the last segment of Octants pattern is delivered, the system returns to the initial subset of Octants when Auto-Transition feature is set to No Transition.

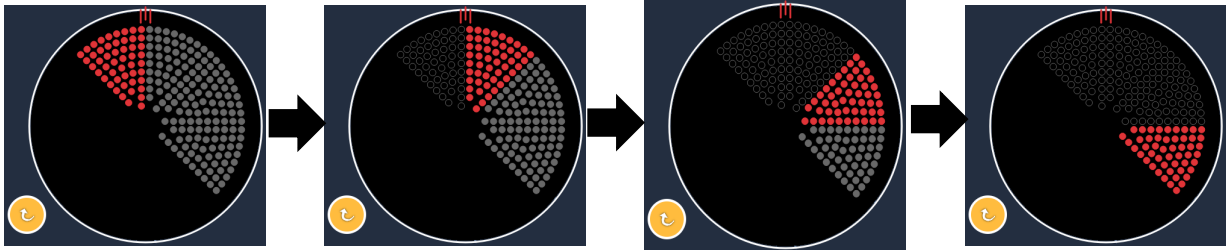

*System Automatically Advances Pattern Clockwise when Auto Advance Feature is Enabled*

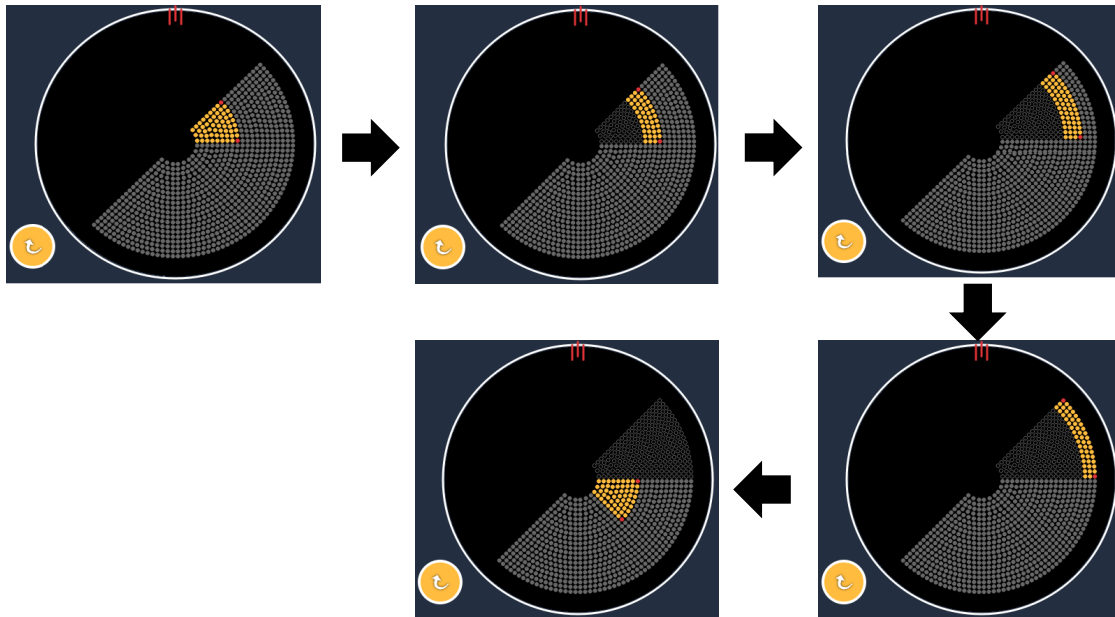

*System Automatically Advances to Next segment when Auto Advance Feature is Enabled*

The orientation is selectable in clockwise and counter-clockwise on the Physician Preferences.



**NOTE**

- *When auto-advanced mode is not enabled, the treated segment spots will also be marked as hollow for enhanced octant pattern.*

### Endpoint Management Features

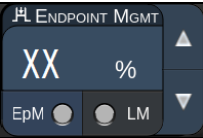
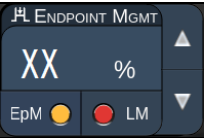
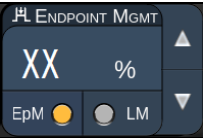
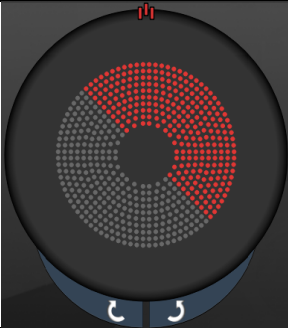
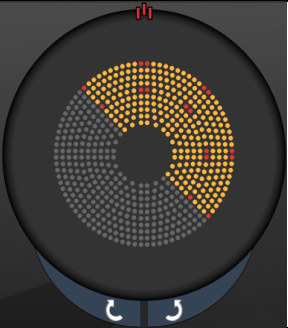
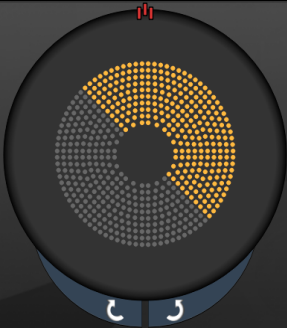
Endpoint Management Off or Disabled	Endpoint Management On/ Landmark On	Endpoint Management On/ Landmark Off
		
<p>All full-power spots (red-100%)</p>	<p>Four full-power spots (red-100%) per octant; remaining endpoint spots (orange-xx %)</p>	<p>All endpoint spots (orange-xx %)</p>
		

### Enhanced Octants

	Primary pattern	Secondary pattern
<b>15ms EpM Enhanced Octants</b>		Not available

See the section “Posterior Pattern Description/Pattern Parameters” for the detailed information on the Enhanced Octants pattern.

### Auto-Transition Feature

In 15ms EpM Enhanced Octant pattern, if Array or Hexagon pattern is selected in Auto-Transition after Enhanced Octants at Physician Preferences screen, it allows the user to transition to the selected pattern automatically after treating the last subset of Octants and to STANDBY mode.



In the case of Array pattern selected





In the case of Hexagon pattern selected

Auto-Transition after Enhanced Octants

**NOTE**

- *The LM will be automatically turn off for any auto transitioned pattern after completing the whole EpM enhanced octants pattern. The LM can be enabled if needed.*
- *When auto-advanced mode is not enabled, there is no auto-transit to configured array or hexagon pattern after completing one segment for EpM enhanced octants pattern.*
- *When auto-advanced mode is not enabled, the treated segment spots will also be marked as hollow for enhanced octant pattern.*

## Endpoint Management Features

Endpoint Management On/ Landmark On	Endpoint Management On/ Landmark Off
	
<p>Four full-power spots (red-100%) per octant; remaining endpoint spots (orange-xx %)</p>	<p>All endpoint spots (orange-xx %)</p>
	



### NOTE

- *The EpM is always ON for all patterns in EpM group. It cannot be disabled.*

## Array

	Primary pattern	Secondary pattern
15ms EpM Array		

See the section “Posterior Pattern Description/Pattern Parameters” for the detailed information on the Array pattern.

## Endpoint Management Features

Pattern Type	Endpoint Management On/ Landmark On	Endpoint Management On/ Landmark Off
1x2, 2x1, 2x2	All full-power spots (red-100%) 	All endpoint spots (orange-xx %) 
Single-column or single row arrays with at least 3 spots	Two full-power spots (red-100%); remaining endpoint spots (orange-xx %) 	All endpoint spots (orange-xx %) 
All other arrays	Four full-power spots (red-100%); remaining endpoint spots (orange-xx %) 	All endpoint spots (orange-xx %) 





## NOTE

- *The EpM is always ON for all patterns in EpM group. It cannot be disabled.*
- *The Landmark is always off for Array's 2×2 sub pattern in EpM group. It cannot be enabled.*

### Hexagon

	Primary pattern	Secondary pattern
15ms EpM Hexagon		

See the section “Posterior Pattern Description/Pattern Parameters” for the detailed information on the Hexagon pattern.

### Endpoint Management Features

# of Spots	Endpoint Management On/ Landmark On	Endpoint Management On/ Landmark Off
7	Six full-power spots (red-100%); remaining endpoint spots (orange-xx %) 	All endpoint spots (orange-xx %) 
19		
37		



### NOTE

- The EpM is always ON for all patterns in EpM group. It cannot be disabled.

### Single Spot

	Primary pattern	Secondary pattern
15ms EpM Single Spot		Not available

### General Use

- PRP, retina tears, retina detachments, iridotomy, trabeculoplasty, LIO

Pattern	Spot Diameter (µm)	EPM %
Single Spot	100 µm	10 to 95
	200 µm	

The Single Spot pattern can be used with the slit lamp or an optional laser indirect ophthalmoscope (LIO). Spot diameter and repetition rate settings are adjustable.



### NOTE

*The Power and Exposure settings cannot be adjusted for 15ms EpM Single Spot pattern. The Power and Exposure settings keep the same as the previous selected EpM pattern.*

### Endpoint Management Features

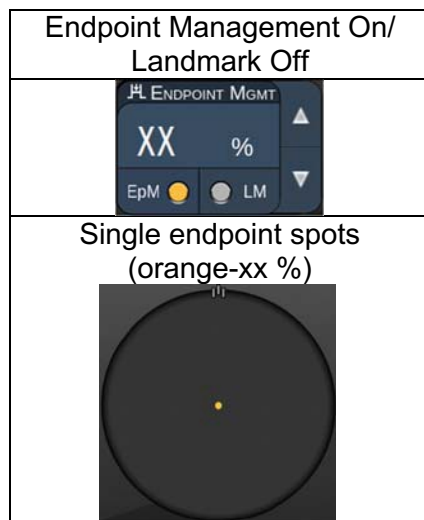



## NOTE

- *The Endpoint Management feature is not available with the LIO.*
- *The Endpoint Management feature is only available for EpM ON and LM OFF mode*

## Anterior Pattern Descriptions/Pattern Parameters

There are two anterior pattern types. The Single Spot patterns and Array (20ms default) are available in the Anterior Treatment screen.

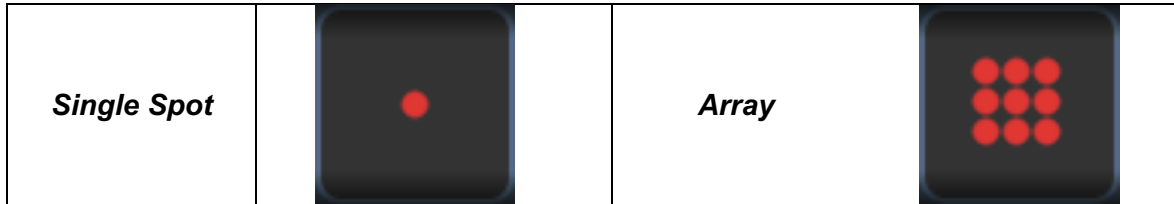

**Primary Pattern**

See the section “Posterior Pattern description/Parameters” for the detailed information on the Single Spot pattern.



### NOTE

- *The Endpoint Management feature is not available in the Anterior Treatment*

## Array

	Primary pattern	Secondary pattern
Array		

## General Use

- retina tears, retina detachments

Pattern	Spot Diameter ( $\mu\text{m}$ )	Spacing
Array	50 (2x2 or smaller),	0.00 $\emptyset$ to 3.00 $\emptyset$
	100	
	200	
	400	0.00 $\emptyset$ to 1.50 $\emptyset$

The Array (20 ms default) pattern is selectable in a variety of shapes and sizes up to a maximum of 9 spots, including square arrays, rectangle arrays, vertical and horizontal lines of up to 3 spots, and a single spot. Spot diameter and spacing settings are also adjustable.

To select the Array pattern shape and size, drag your finger horizontally, vertically, or diagonally across the pattern, or press one of the quick-select buttons at the bottom of the secondary pattern screen. To select the pattern orientation, press <Rotate> button at the bottom of the screen.

## Pattern Titration



<b>A</b>	<Titrate>— press to switch to Titrate Mode to perform test lesions in a linear pattern, adjustable from 1 to 4 spots; press again to revert to prior laser mode
<b>B</b>	Power Display – Maximum and Minimum are displayed when 2 or more applications are selected.
<b>C</b>	<Spacing>—1.0 to 2.0 diameters
<b>D</b>	Titration Pattern—press to select number of titration applications

<Titrate> provides the option to deliver 1 to 4 laser applications in a linear pattern to facilitate selection of desired laser dosimetry. Power within the titration pattern decreases from left to right, starting with the full power setting and decreasing by one power increment for each spot, moving to the right across the pattern. The titration increment will vary depending on the full power setting and corresponds to the incremental step change in power shown by adjusting the power down arrow, e.g. a 4-spot titration pattern starting at 175 mW will deliver 175mW→150mW→ 140mW→130mW.



### WARNING

*Please confirm that Endpoint MGMT is automatically disabled and grayed out during titration mode.*

*Performing titration when EndPoint Management is turned on may result in overpower exposure.*

*Refer to Warning Section for Pattern Titration Warning Information.*



**NOTE**

- *The pattern selection bar is disabled when Titration is ON.*

## Endpoint Management with Landmark Patterns (optional)

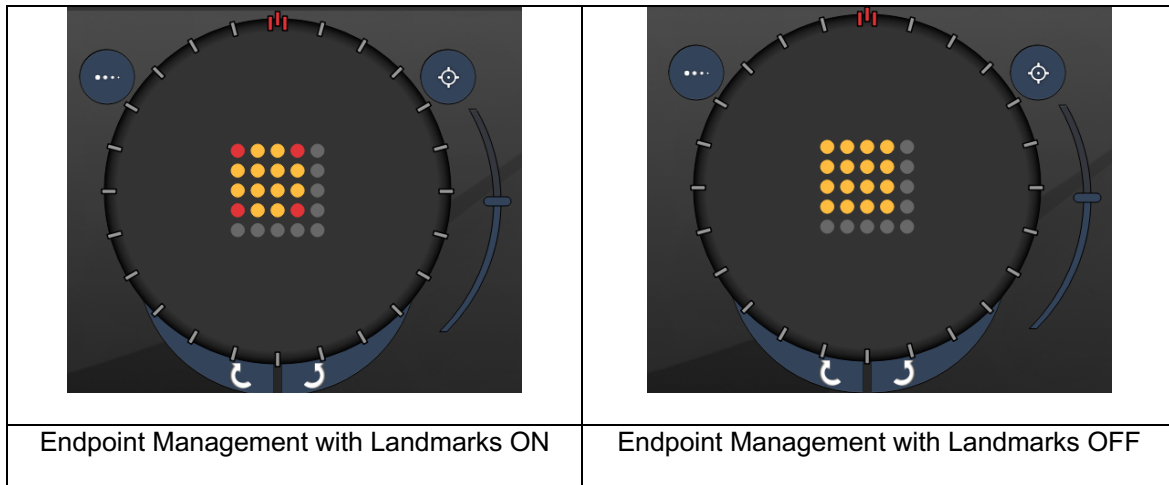

**EpM (Endpoint Management):** Refers to a software feature that allows delivery of laser energy which is a user-selected percentage of a laser dose pre-determined by titration. This pre-determined titration dose is the “100%” level, corresponding to the energy produced by the displayed “power” and “exposure” parameters on the Treatment Screen, and is expected to be determined by ophthalmoscopically visible (sub-visible) test burns delivered by the physician. With Endpoint Management enabled, the laser power and exposure duration are reduced to deliver the user-selected percentage of the output energy settings. For example, if the user titrates to a power/exposure duration setting that delivers 4 mJ laser energy, an EpM setting of 75% would provide 3 mJ for each exposure. Duty cycle within each laser pulse remains constant (100% duty cycle) with Endpoint Management.

EpM percentage ranges from 10% to 95%.

To increase the dose above the 100% level, the user is expected to re-titrate laser power with additional test burns. By providing fine control over delivered energy, EpM allows the user to control the laser output to levels where ophthalmoscopically visible lesions are not achieved, while referencing a dosage with a visible effect (the 100% dosage).

The EpM features are only enabled on retinal treatment patterns for use in retinal photocoagulation. The use of EpM is otherwise restricted by the physician.

**LM (Landmark):** Refers to a feature of the Endpoint Management software application that allows delivery of two energy dose levels within a single pattern. When EpM is enabled, the user can optionally enable Landmark patterns. With EpM enabled, the outermost spots, the LM exposures, in the pattern are set to the 100% dosage (100% nominal power and exposure duration displayed on the treatment screen), while the inner spots are delivered at the current EpM % setting. With EpM enabled and Landmarks disabled, the entire pattern is delivered at the current EpM % setting.

The purpose of LM patterns is twofold – to indicate the location of patterns delivered with EpM, which may be less ophthalmoscopically visible than the 100% exposures, and to provide visual feedback to the physician for dosimetry. In treatments without the use of Endpoint Management, it is routine for physicians to use the visual appearance of lesions to guide their adjustment of laser power in order to maintain a constant lesion grade.

Exposures with a low EpM % setting do not provide such guidance, but by delivering the outermost spots (the Landmarks) in the pattern at the full 100% titration dose, this visual cue is maintained. As the Landmark burns in the pattern vary in effect as the laser application is

---

moved across the retina, the user can adjust the laser power to maintain the same lesion appearance as the original titration burn.

# System Software Setup

## System Setup Screen

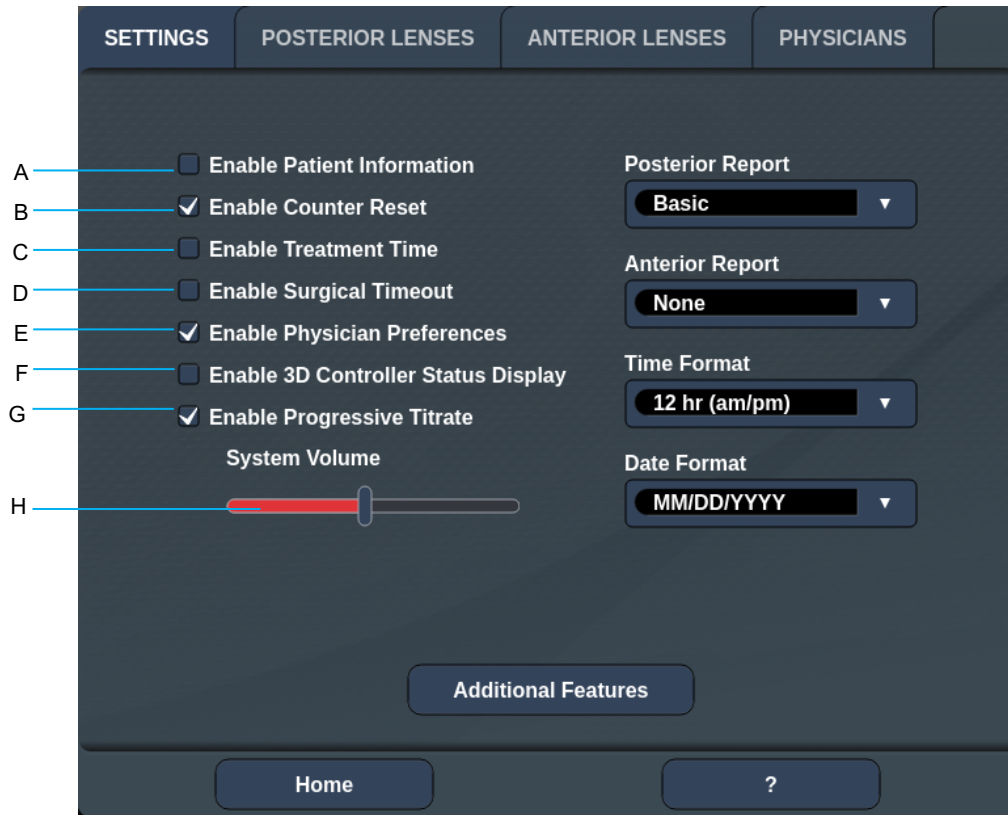

<b>A</b>	<Patient Information> - Enable/Disable Patient information pop-up prior to treatment
<b>B</b>	<Counter Reset> - Enable/Disable resettable counter in <Treatment Screen>
<b>C</b>	<Enable Treatment Time> - select to display treatment time and date on Treatment screen and report
<b>D</b>	<Surgical Timeout> - Enable/Disable screen to review patient information (prior advancing to <Treatment Screen>)
<b>E</b>	<Physician Preferences> - Enable/Disable Physician List and Information
<b>F</b>	<Enable 3D Controller Status> - Enable/Disable 3D Controller disconnect notification
<b>G</b>	<Enable Progressive Titrate> - Enable/Disable Progressive titrate
<b>H</b>	<Volume> - slide to adjust system volume (cannot turn off)

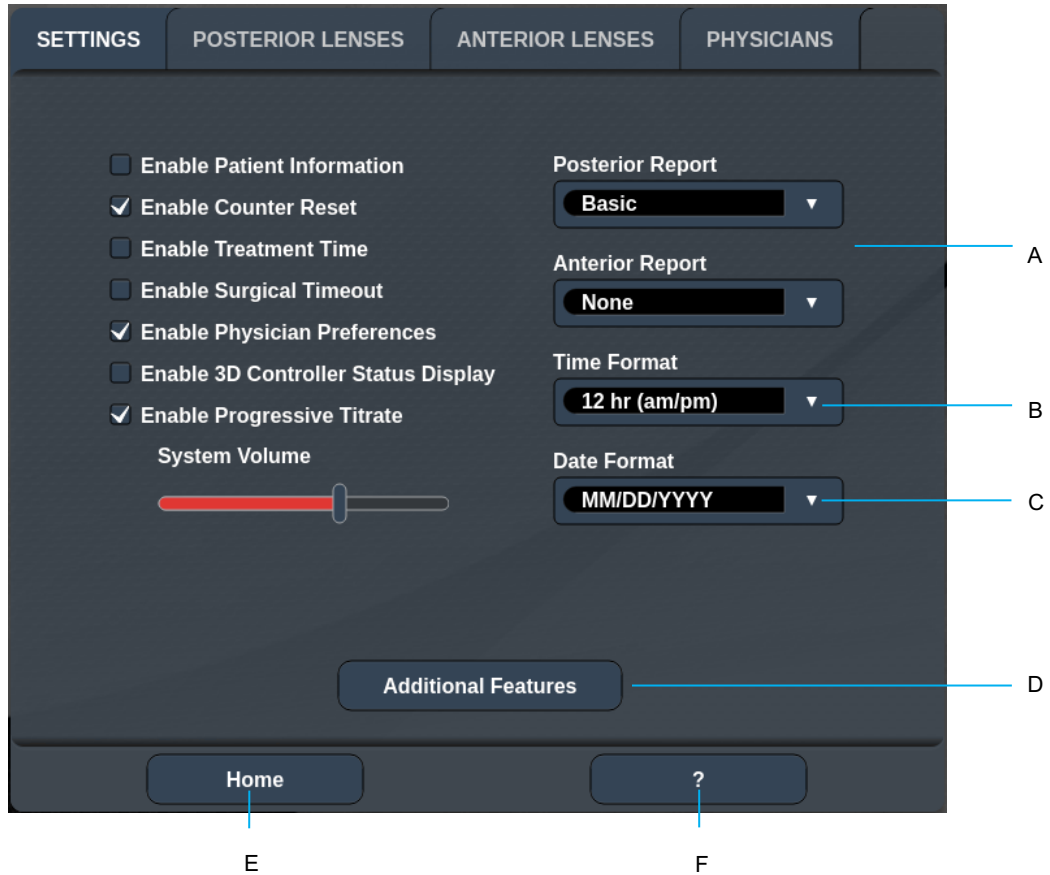

<b>A</b>	<Report> - press to select report format
<b>B</b>	<Time Format> - press to select time format
<b>C</b>	<Date Format> - press to select date format
<b>D</b>	<Additional Features> - Enter activations codes for optional upgrades
<b>E</b>	<Home> - press to go to Home screen
<b>F</b>	<?> - press to go to Help screen



## NOTE

- Refer to “Treatment Reports” section for detailed information on report format.

## Patient Information Feature

The Patient Information feature allows you to include patient identification, such as patient name, number, and date of birth, on Treatment screen and Treatment Report. Press the **Enable Patient Information** checkbox on the System Setup screen to enable the Patient Information feature.

When the Patient Information feature is enabled, the following window displays when you press the Posterior Treatment or Anterior Treatment button on the Home screen.

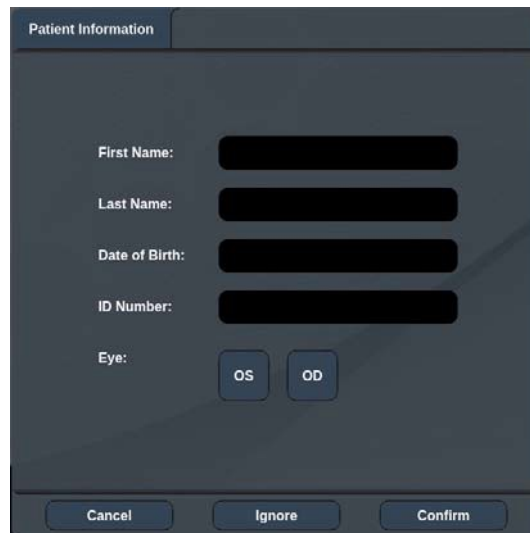

**<Patient Information> Window**

To enter the patient information:

1. Press the First Name field, enter the information using the on-screen keyboard, and then press **OK**.
2. Press the Last Name field, enter the information using the on-screen keyboard, and then press **OK**.
3. Press the Date of Birth field, enter the information using the on-screen keyboard, and then press **OK**.
4. Press the ID Number field, enter the information using the on-screen keyboard, and then press **OK**.

5. Press the  or  button to select the appropriate eye.

6. Press Confirm button to save information and proceed to the Treatment screen.

The information you entered in the Patient information window is displayed on the Treatment screen and the Treatment Report.



## Progressive Titrate

When the Progressive Titrate feature is enabled, it allows you to output an aiming beam pattern with positions that are offset from the delivered with 1.5 spot diameter spacing between the titration pattern and the blinking aiming spots. If the titration pattern spots have reached at the top of the FOV, the blinking aiming spots stay at the same position of the titration pattern spots. The location of titration is set to the initial position of the titration when you press **Titrate** button to revert to the treatment mode. Press the **Enable Progressive Titrate** checkbox on the System Setup screen to enable the Progressive Titrate feature.

### <Physician Preferences> Window

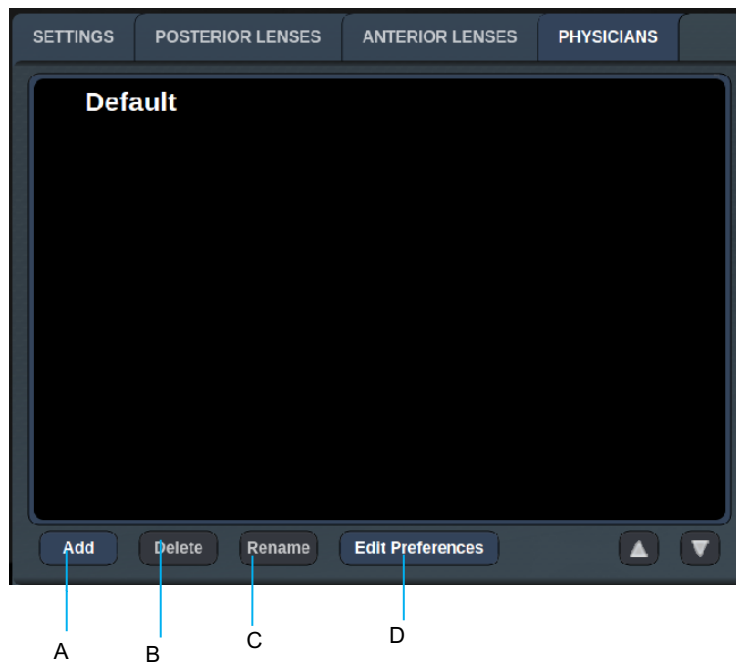

<b>A</b>	<Add> - press to add physician
<b>B</b>	<Delete> - press to remove physician
<b>C</b>	<Rename> - press to rename physician
<b>D</b>	<Edit Preferences> - press to open <Edit Physician Preferences> window

## <Edit Physician Preferences> Window

Normal Feature

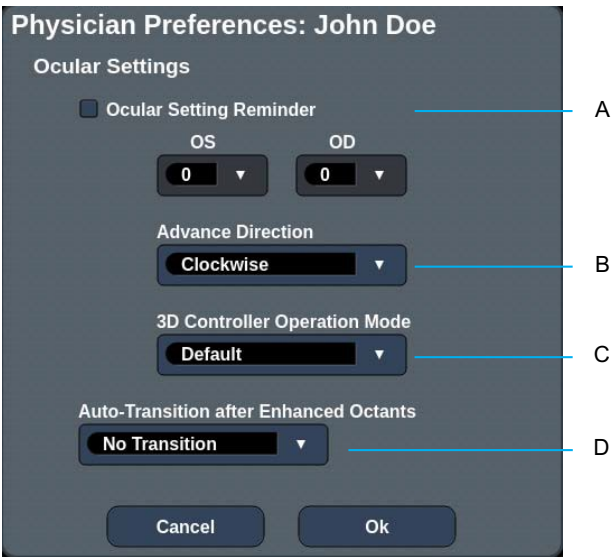

<b>A</b>	<Ocular Setting Reminder> - displays settings to remind to set ocular power before treatment.
<b>B</b>	< Advance Direction> - select direction to advance the pattern
<b>C</b>	<3D Controller Mode> - set to Advanced or Default configuration
<b>D</b>	<Transition> - will advance to pattern after Enhanced Octant is completed (available when Endpoint Management is activated).

## Contact Lens Selection Screen

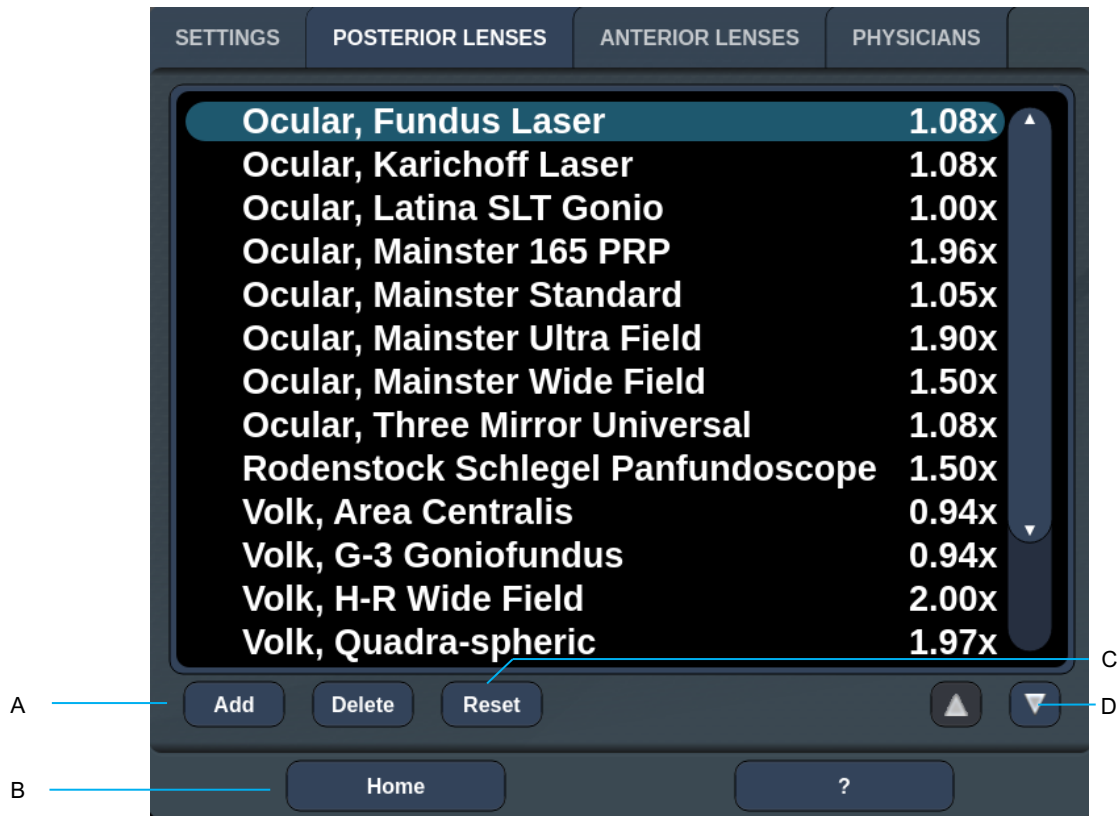

<b>A</b>	<Add>—press to enter custom lens <Delete>—press to delete lens
<b>B</b>	<Home>—press to go to Home screen
<b>C</b>	<Reset>—discard changes
<b>D</b>	Up/Down—press to scroll

## Favorites Window

Press the favorite icon in the posterior/anterior treatment screen to open the Favorite Window.



Display favorite details information (pattern, power, exposure, spot diameter, spacing, lens) when the favorite entry is pressed and held for 1 second in the favorite list. Click the popup or other place to close the popup. If the favorite is pressed and released shorter than 1 second, the favorite will be loaded.

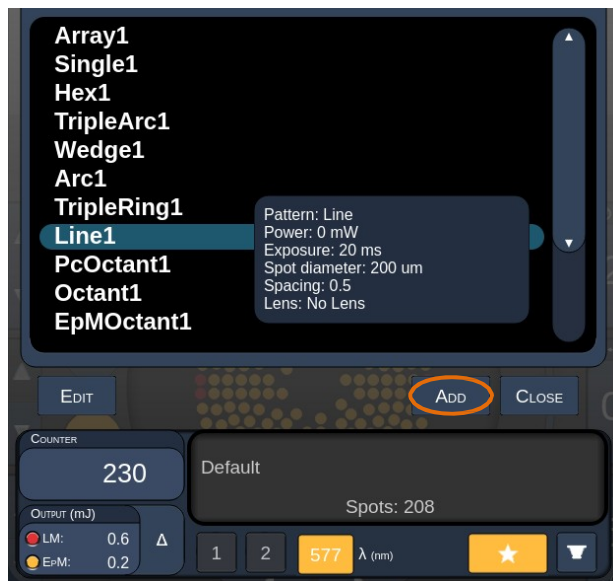

Click “Add” button and enter the name for the favorite to save the current parameter setting as your favorite.



Once a favorite is loaded, the favorite name will be displayed in status area.

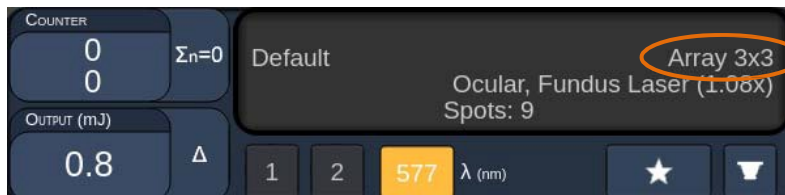

## NOTE

- *If any parameter is changed, the favorite name in status area will be cleared.*

## <Edit Favorites> Window

Press the “Edit” button to enter the Edit mode.

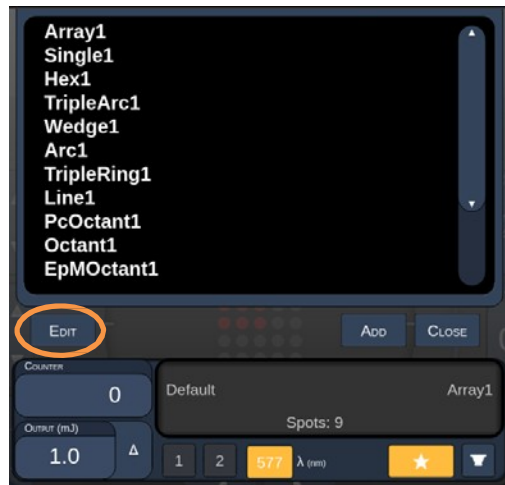

Once a favorite is selected, the “Rename”, “Remove”, “Save” and “Move” buttons are enabled.



<b>A</b>	<Done> - press to finish the Edit of Favorite Window
<b>B</b>	<Rename> - press to change the name of the selected favorite
<b>C</b>	<Remove> - press to remove the selected favorite from Favorites Window
<b>D</b>	<Save> - press to save the edit for the selected favorite
<b>E</b>	<Move> - press to reorder the favorite list
<b>F</b>	<Close> - press to close the Favorite Window

Press the “Move” button to start the move operation. Notice the “Move” button is change to “Cancel Move” which can be used to cancel the move operation. Select the favorite whose position you want to move the previously selected favorite to.

For example, select “Single 1”. The software will move “Wedge 1” to the position 2.

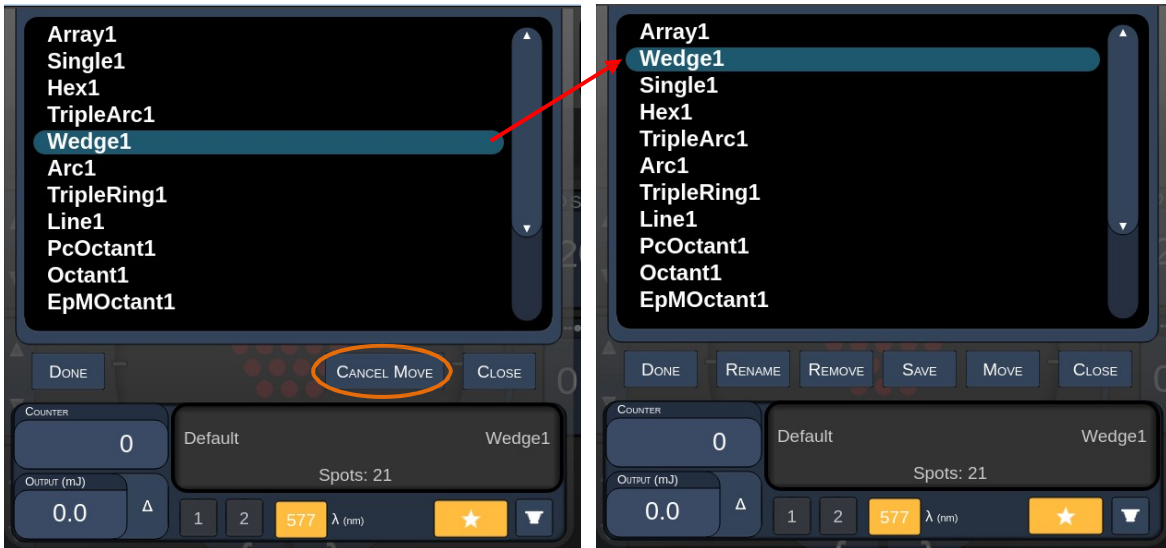

## Treatment Report Window

If you have enabled reports on the System Setup screen (see “System Setup Screen” section), the Treatment Report Window displays when you press the **End Treatment** button at the completion of each patient treatment session.

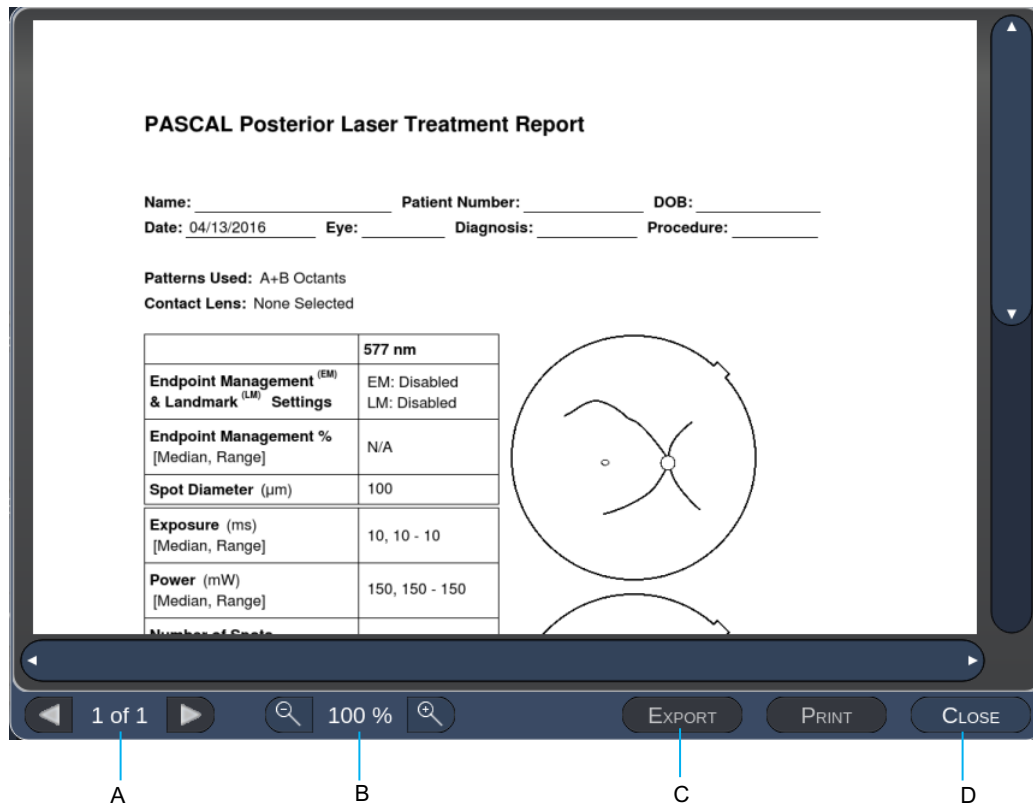

<b>A</b>	<Page> - press  to show the previous page and  to show the next page (when applicable)
<b>B</b>	<Zoom> - press  to zoom out and  to zoom-in the preview
<b>C</b>	<Export> - Press to export the treatment report to the connected USB drive.
<b>D</b>	<CLOSE> - press to close the Treatment Report Window to go to Home Screen



### NOTE

- Once the system is returned to the Home screen by selecting the **CLOSE** button, the current session treatment report is no longer available.

- 
- *The “Export” is disabled if no USB drive is plugged into the console’s USB port.*

## Export Treatment Report

The Export button will be enabled if a USB drive is plugged into the console's USB port and detected by the Synthesis software. If the connected USB drive doesn't meet the requirements, the "Export" button is still disabled and the system will pop up the message.



All the reports exported from Synthesis will be stored in the 'synthesis\_report' folder in the USB drive. The user can plug in the USB drive to a PC to copy or delete the exported reports.

The USB drive should be dedicated for the Report Export purpose. Any other usage will make it incompatible for Report Export, in which case you will have to reformat it according to the "Procedure to prepare the USB drive before the first time use" (refer to Page 95).



### NOTE

- *Requirement for the USB drive to be used for Report Export in Synthesis v3.6.0:*
  - *USB 2.0 or 3.0*
  - *8GB or larger*
  - *FAT32 file system*

## Procedure to prepare the USB drive before the first time use

Purchase a new USB drive of USB 2.0 or USB 3.0 with at least 8GB in size.  
On a Windows 10 PC, open Windows Explorer, plug in the USB drive, identify the newly added drive.

Here is the example to format a new USB. Drive letter E is just an example in the picture below, it could be different on a different PC.

- Right click the newly added USB drive, select “Format...” from the pop up menu to open the Format window.

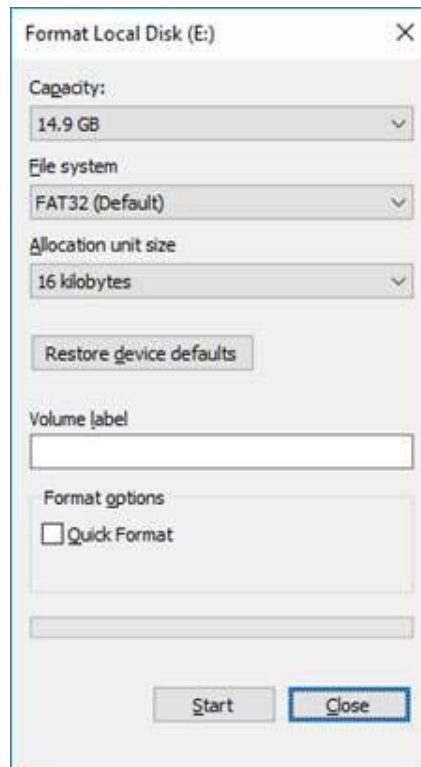

- Select FAT32 for File system. Uncheck the Quick Format checkbox. Click Start button. Wait until the format is finished.



### WARNING

*Selecting a wrong drive for format will ERASE ALL the data on that drive. Make sure the newly added USB drive is selected for format.*

## ***Treatment Reports***

At the completion of each patient session, you can view a Treatment Report, if desired. Reports can be enabled or disabled from the System Setup screen. Three report templates are available:

- Posterior Basic Info Treatment Report
- Posterior Advanced Info Treatment Report
- Anterior Basic Info Treatment Report

Preferences for Posterior Reports and Anterior Report can be set separately. Refer to the following pages for a sample of each report.

### PASCAL Posterior Laser Treatment Report

Name: \_\_\_\_\_ Patient Number: \_\_\_\_\_ DOB: \_\_\_\_\_  
 Date: \_\_\_\_\_ Eye: \_\_\_\_\_ Diagnosis: \_\_\_\_\_ Procedure: \_\_\_\_\_

**Patterns Used:** Triple Arc, A+B Octants (15 ms), Hexagon (15 ms), Octants  
**Contact Lens:** Volk, SuperQuad 160 (2.00x), Ocular, Fundus Laser (1.08x), Rodenstock Schlegel Panfundoscope (1.50x)

	<b>577 nm</b>
<b>Endpoint Management<sup>(EM)</sup> &amp; Landmark<sup>(LM)</sup> Settings</b>	EM: Disabled LM: Disabled
<b>Endpoint Management %</b> [Median, Range]	N/A
<b>Spot Diameter (µm)</b>	100, 200
<b>Exposure (ms)</b> [Median, Range]	15, 10 - 30
<b>Power (mW)</b> [Median, Range]	100, 0 - 1000
<b>Number of Spots</b> [Total, (#LM, #EM)]	771 (771, 0)
<b>Energy (mJ)</b> [Median, Range]	18, 0 - 960
<b>Fluence (J/cm<sup>2</sup>)</b> [Median, Range]	4.1, 0.0 - 81.9

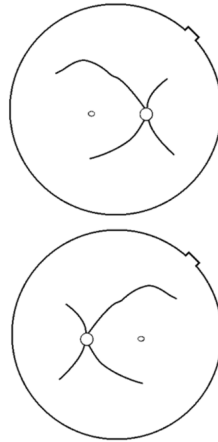

Treatment Time: 30:00 (mm:ss)

**Note:**

\_\_\_\_\_ MD  
 \_\_\_\_\_ Signature  
 \_\_\_\_ / \_\_\_\_ / \_\_\_\_ Date

*Sample Posterior Info Treatment Report*

### PASCAL Posterior Laser Treatment Report

Name: \_\_\_\_\_ Patient Number: \_\_\_\_\_ DOB: \_\_\_\_\_  
 Date: \_\_\_\_\_ Eye: \_\_\_\_\_ Diagnosis: \_\_\_\_\_ Procedure: \_\_\_\_\_

**Total # of Spots:** 784    **Patterns Used:** Triple Arc, arc, A+B Octants, Octants (15 ms), Hexagon (15 ms), Octants  
**Power (mW):** 100    **Spot Diameter** 100, 200    **Exposure (ms)** 15,  
 [Median, Range]: 0 - 1000    (µm):    [Median, Range]: 10 - 30  
**Contact Lens:** Volk, SuperQuad 160 (2.00x), Ocular, Fundus Laser (1.08x), Rodenstock Schlegel Panfundoscope (1.50x)

λ	Patterns	# Spots	Power (mW) [Median, Range]	Exposure (ms) [Median, Range]	EM % [Median, Range]	Spot Spacing (Φ)	Energy (mJ) [Median, Range]
577 nm	Triple Arc	125 (125, 0)	300, 225 - 300	20, 20 - 20	N/A	0.5, 1.5	93.4 - 186
	arc	100 (100, 0)	1000, 1000 - 1000	30, 30 - 30	N/A	0.25	960, 810 - 1200
	A+B Octants	112 (112, 0)	100, 100 - 100	10, 10 - 10	N/A	1.5	14, 14 - 14
	Octants 15ms	208 (16, 192)	100, 100 - 100	15, 10 - 15	30, 30 - 30	0.25	14, 9 - 14
	Hexagon 15 ms	95 (30, 65)	100, 100 - 100	15, 15 - 15	30, 30 - 30	2	15, 15 - 15
	Octants	144 (144, 0)	0, 0 - 0	10, 10 - 10	N/A	1.5	0, 0 - 0

Total Area Treated (mm<sup>2</sup>): 31.38    Total Energy Delivered (mJ): 4004.5

Treatment Time: 00:30 minutes    Fluence (J/cm<sup>2</sup>) 1.2, 0.0 - 81.9  
 [Median, Range]:

**Endpoint Management<sup>(EM)</sup>  
 & Landmark<sup>(LM)</sup> Settings**    EM - On, LM - On

\_\_\_\_\_ MD

\_\_\_\_\_ Signature

\_\_\_\_\_/\_\_\_\_\_/\_\_\_\_\_ Date

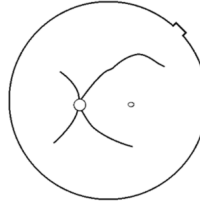
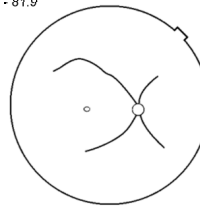

*Sample Posterior Advanced Info Treatment Report*

**PASCAL Anterior Laser Treatment Report**

Name: \_\_\_\_\_ Patient Number: \_\_\_\_\_ DOB: \_\_\_\_\_  
 Date: \_\_\_\_\_ Eye: \_\_\_\_\_ Diagnosis: \_\_\_\_\_ Procedure: \_\_\_\_\_

Patterns Used: PSLT, Array (Ant.)  
 Contact Lens: Ocular, Latina SLT Gonio (1.00x)

	577 nm Titration	577 nm Summary
Spot Diameter (µm)	100	100
Exposure (ms) [Median, Range]	10, 10 - 10	5, 5 - 20
Power (mW) [Median, Range]	85, 70 - 100	100, 100 - 200
Number of Spots	4	1278
Energy (mJ) [Median, Range]	1, 1 - 1	20, 6 - 20
Fluence (J/cm <sup>2</sup> ) [Median, Range]	10.8, 8.9 – 12.7	6.4, 6.4 - 25.5
Treatment Plan		360°
Total Angle Treated		360°

Note:

\_\_\_\_\_ MD  
 \_\_\_\_\_ Signature  
 \_\_\_\_ / \_\_\_\_ / \_\_\_\_ Date

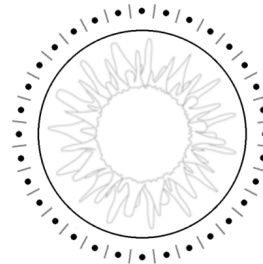

*Sample Anterior Basic Info Treatment Report*



**NOTE**

*The graphical depiction of the area treated on the Anterior Laser Treatment Report represents the physical area of the TM that was treated during the procedure. If any areas of the TM were retreated during a treatment, these areas will be visually depicted with a solid circle.*

## Intraoperative Instructions

### *Slit Lamp Treatment Procedure*

Perform the following procedure:

1. Verify that the slit lamp eyepieces are adjusted to your settings.
2. Position the patient at the slit lamp with their chin on the chin rest and forehead pressed firmly against the head rest.
3. Select the laser treatment spot diameter, exposure time, treatment power level, and pattern type.
4. Position the contact lens on the patient's eye.
5. Select READY mode. The aiming beam will turn on.
6. Adjust the aiming beam intensity.
7. Adjust the pattern spacing, radius, and/or curvature, if applicable.
8. Focus the slit lamp and observe the red aiming beam imaged on the patient's eye. Verify that the laser spots are round and that the pattern is undistorted. Establish proper placement of the laser beam with the slit lamp joystick.
9. Press <Titrates> to switch to a single spot and perform test burns at the periphery of the treatment area.
10. Adjust the laser treatment power for therapeutic effect, and then press <Titrates> again to revert to the selected pattern.
11. Prior to treatment, verify that the power and other parameters are within acceptable ranges.
12. Depress and hold down the footswitch to deliver the treatment laser beam to the tissue. Each footswitch depression will result in **one scanned pattern** unless the treatment is terminated prematurely by early release of the footswitch. Treatment may be interrupted at any point by releasing the footswitch.



### NOTE

- *Always place the system in STANDBY mode if there is a prolonged pause in treatment.*
- *If the system is in READY mode and remains idle for 5 minutes, it automatically reverts to STANDBY mode, and the touchscreen control panel becomes light gray. To resume activity, touch the screen. The Status control displays "<START UP>" for approximately 90 seconds until the system is ready again.*

## ***LIO Treatment Procedure***

Perform the following procedure in conjunction with the instructions in the Laser Indirect Ophthalmoscope (LIO) operator manual.

1. Select the Port where the LIO is connected.
2. Select READY mode. The aiming beam turns on.
3. Select the aiming beam intensity.
4. Select the appropriate exposure time.
5. Select the appropriate laser power.
6. Make any necessary adjustments to the headset to ensure safe and clear view of the retina, as described in the LIO operator manual.
7. Position the aspheric lens and select the spot diameter, as described in the LIO operator manual.



### **NOTE**

- *When using the LIO, the laser spot diameter cannot be adjusted. Spot diameter is determined by the choice of aspheric lens and the position of the LIO relative to the target tissue. See the LIO operator manual for detailed information.*
8. Depress the footswitch to deliver the treatment laser beam to the tissue.

---

## ***Between Patient Treatments***

At the completion of each patient treatment:

1. Press <End Treatment>to exit the Treatment screen. If the treatment report feature is enabled, the Treatment Report window displays. Otherwise, the Home screen displays.



### **NOTE**

*If no laser shots were fired during the treatment session, pressing <End Treatment>returns the system to the Home screen whether or not the treatment report feature is enabled.*

2. Disinfect the chin rest and head rest using mild soap and water. Dry with a soft cloth.
3. Disinfect the contact lens following the contact lens manufacturer instructions.

## ***System Shut-down***

At the end of the day, or during an extended period of inactivity:

1. Shut down the system as described in “Shutting Down the System”.
2. Remove the key to prevent unauthorized use of the system.
3. Clean the system as described in “User Maintenance”.
4. Place a dust cover over the slit lamp.

## **Maintenance Instructions**

To assure that the system remains safe with regard to electromagnetic disturbance throughout the expected service life, the following actions are recommended.

### ***Annual Maintenance***

Preventive maintenance, safety, power and calibration checks should be performed annually by Iridex Corporation-certified personnel to ensure proper laser performance.

### ***System Repair***

All repairs should be performed by certified personnel to ensure proper system performance.

### ***User Maintenance***

The following maintenance procedures are to be performed by the user to ensure proper performance of the system.

### ***Cleaning the Console External Surfaces***

Clean the external surfaces of the console daily, after use. Use a cloth dampened with a non-caustic cleaning solution (e.g., soap and water) to clean the external non-optical surfaces of the console. Dry with a clean cloth or allow to air dry. Do not spray or pour cleaning agents directly onto the console.

### ***Cleaning the Control Panel Screen***

Use a soft, dry cloth to apply antistatic glass or plastic cleaner to the control panel screen.

### ***Maintaining Effectiveness of Grounds***

Clean the unplugged power cord to maintain the protective earth. Use a soft, dry cloth.

## Replacing the Fuses

To change the power receptacle fuses:

1. Ensure the key switch is in the OFF position.
2. Unplug the main power cable from the wall outlet and the system main power receptacle.
3. Insert a small, insulated flathead screwdriver into the fuse holder release receptacle and unlock and remove the fuse holder.

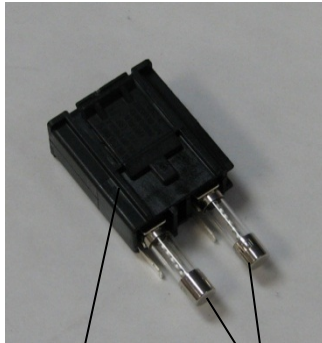

Fuse holder

Fuses



Location of  
system fuses

Main power  
cord receptacle

4. Replace the blown fuses with new fuses compatible with the mains supply voltage, as indicated in the <System Specifications> section of this manual.
5. Replace the fuse holder.

## System Specifications

[Specifications are subject to change without notice.]

<b><i>Treatment Beam</i></b>		
	<b>PASCAL Synthesis (532 nm)</b>	<b>PASCAL Synthesis (577 nm)</b>
Type	Optically Pumped Semiconductor Laser (OPSL)	
Wavelength (nm)	532	577
Power output (mW)	0 – 2000	
Duty cycle	100%	
Pulse durations (ms)	10 – 1000	
Pulse interval	1, 1.5, 2, 3, 4, 5, 6, 7 and 8 Hz (single spot or LIO)	
Pulse counter	0 – 99,999	
Laser beam diameter	50, 100, 200, 400 $\mu$ m (in air)	
CDRH classification	Class IV	
European MDD laser classification	Class 4	
<b><i>Aim Beam</i></b>		
Type	Laser Diode	
Wavelength (nm)	635	
Power output	< 1 mW	
CDRH classification	Class II	
European MDD laser classification	Class 2	

<b>Electrical Requirements</b>		
	<b>PASCAL Synthesis (532 nm)</b>	<b>PASCAL Synthesis (577 nm)</b>
Voltage	100-240V~, 50/60Hz	
Rated power	200VA	
Fusing	200VA T2AH 250V	
Fan noise	< 55 dBA	
<b>Product Classifications per IEC 60601-1</b>		
Class I equipment		
Type B equipment		
Standard equipment, Footswitch is IPX1		
Non-sterile product		
Equipment not suitable for use in the presence of a flammable anesthetic mixture with air or with oxygen or nitrous oxide		
Continuous operation		
<b>Classifications &amp; Approvals</b>		
EN/IEC 60601-2-22	Laser Safety Requirements for Diagnostic and Therapeutic Laser Equipment	
EN/IEC 60601-1	International Safety Requirements for Medical Electrical Equipment	
EN/IEC 60601-1-2	EMC Requirements for Medical Electrical Equipment	
ISO 14971	Risk Management for Medical Devices	
CAN/CSA-C22.2 No. 60601-1	Canadian deviations for Medical Electrical Equipment	
ANSI/AAMI ES 60601-1	US Safety Requirements for Medical Electrical Equipment	
EN/IEC 60825-1	Safety of laser products	
FCC	Tested and Complies With FCC Part 15 Class B	

<b>Environmental Requirements (operating)</b>		
	<b>PASCAL Synthesis (532 nm)</b>	<b>PASCAL Synthesis (577 nm)</b>
Maximum altitude	2,000m (6562 ft.)	
Operating temperature	15° – 35°C (59° – 95°F)	
Maximum humidity	15° to 25°C: 85% (non-condensing) 25° to 35°C: 60% (non-condensing)	
Atmospheric pressure range	80.0 – 106.0 kPa	
<b>Environmental Requirements (non-operating)</b>		
Maximum altitude	Standard commercial shipping altitude	
Non-operating temperature	-10° to +55°C (14° to 131°F)	
Maximum humidity	85% (non-condensing)	
Atmospheric pressure range	70.0 – 106.0 kPa	
<b>Physical Characteristics</b>		
	<b>PASCAL Synthesis (532 nm)</b>	<b>PASCAL Synthesis (577 nm)</b>
Console height	9 in (23 cm)	
Console width	15 in (38 cm)	
Console depth	12 in (31 cm)	
Console weight	< 35 lbs. (< 16 kg)	
Power cable length	3 m (10 ft.)	
Laser fiber and electronics cable	Fiber bundle: 2.7m	
Footswitch cable length	3 m (10 ft.)	
Latex	This product is latex free	
<b>Laser Safety Eyewear</b>		
	<b>PASCAL Synthesis (532 nm)</b>	<b>PASCAL Synthesis (577 nm)</b>
Non-CE eyewear	Minimum OD of 3.8 at 532 nm per ANSI Z136.1	Minimum OD of 3.8 at 577 nm per ANSI Z136.1
CE eyewear	L5 at 532 nm per EN 207 Personal Eye Protection	L4 (minimum OD of 4) at 577 nm per EN 207 Personal Eye Protection

## Troubleshooting Guide

If the instrument fails to operate properly, this troubleshooting guide will help you to locate and correct the malfunction. Should a major malfunction occur, contact service. First, check for the following items. If none of these solutions remedies the problem, consult the service manual for additional troubleshooting options.

1. Verify that the wall circuit breaker is in the ON position.
2. Verify that the power cable is correctly attached to the system and the wall outlet.
3. Verify that the key switch is in the ON position.
4. Verify that the door interlock plug is securely connected and, if a door interlock is in use, that the door switch is closed.
5. Verify that the footswitch cable is securely connected.
6. Verify that the LCD control panel cables are correctly installed.
7. Verify that the emergency laser stop button is not depressed.

***System does not turn on.***

Probable Cause:	System is not plugged in.
Suggestion:	Plug in system. Verify power cable is well seated in wall outlet and in main power receptacle.
Probable Cause:	Wall circuit breaker is in off position.
Suggestion:	Turn on wall circuit breaker.
Probable Cause:	Key is absent or in OFF position.
Suggestion:	Insert key and rotate to ON position.
Probable Cause:	Internal system error.
Suggestion:	Turn key switch to OFF position, wait at least one minute and then turn to ON position. If system fails to start, contact service.

***System monitor is blank for more than 30 seconds.***

Probable Cause:	Internal system error during boot-up.
Suggestion:	Turn key switch to OFF position, wait at least one minute and then turn to ON position.
Probable Cause:	Monitor/touchscreen panel power, USB and signal cables are not correctly connected.
Suggestion:	Ensure that monitor cables are correctly connected.

***3D Controller not functioning.***

Probable Cause:	Loose connection or disconnected from system.
Suggestion:	<p>Ensure that cables are correctly connected. Reboot the system.</p> <p>Attempt to use 3D Controller when in “Standby” mode and confirm parameters can be changed.</p>

***Trouble Adding/Removing Favorites.***

Probable Cause:	Favorite’s Database Update Error.
Suggestion:	Reboot the System.

***No aiming beam is present when in READY mode and/or no laser treatment light is delivered when the footswitch is depressed and/or the beams are of poor quality.***

Probable Cause:	Laser is in STANDBY mode, not READY mode.
Suggestion:	Select READY mode on control panel.
Probable Cause:	Footswitch is not connected.
Suggestion:	Connect footswitch.
Probable Cause:	Aiming beam is on low intensity setting.
Suggestion:	Adjust aiming beam intensity on control panel.
Probable Cause:	After five minutes of non-use, system goes to STANDBY.
Suggestion:	Switch mode from STANDBY to READY.
Probable Cause:	Remote interlock has been activated and has disabled system.
Suggestion:	Ensure the action that activated remote interlock has ceased and proceed.
Probable Cause:	Footswitch and/or footswitch cable damaged.
Suggestion:	Inspect for damage.
Probable Cause:	Internal system error.
Suggestion:	Contact service.

## Error Messages

### Error States

If error occurs regularly, contact service.

**Critical Error** implies a safety issue that requires the system to immediately go to a safe state. System restart may be required.

**Clearable Error** indicates a problem with the system that requires that the system be put into a safe state until the error is acknowledged by the user.

**Warning** indicates a problem with the system that does not represent a serious safety issue and does not require any system functions to be interrupted, but does require that the user be notified.

Code	Message	Critical	Clearable	Warning	Description	Action
01	Kill Line	X			The kill lines were asserted in the hardware	Reboot. Call service if error persists.
02	Emergency Stop		X		The emergency stop switch was pressed.	Release Emergency Stop.
03	Footswitch Connect		X		Footswitch has malfunctioned or been disconnected	Connect Footswitch
04	Power Rails		X		An error was detected with the power supplies.	Reboot. Call service if error persists.
05	Watchdog (Galvo)	X			The watchdog fired; this implies the back-end is taking too long in the ISR, or is in an infinite loop.	Reboot. Call service if error persists.
06	Watchdog (Main)	X			The watchdog fired; this implies the back-end is taking too long in the ISR, or is in an infinite loop.	Reboot. Call service if error persists.
07	Interlock		X		The interlock switch was activated.	Connect Remote Interlock
11	Aiming Current Over (High)		X		Aiming beam output above threshold.	Call service if error persists.
15	OPSL Treatment Current Over (Medium)		X		OPSL laser draws electric current above threshold.	Call service if error persists.
16	OPSL Treatment Current Over (High)		X		OPSL laser draws electric current above threshold.	Call service if error persists.
17	Unexpected OPSL Treatment Current		X		Electric current was drawn by OPSL Laser module when it was not expected	Verify device connections.
28	Base Treatment Temperature Low (Moderate)		X		The base treatment temperature is low	Check fan and ventilation. Allow system to cool.
29	Base Treatment Temperature Low (Severe)	X			The base treatment temperature is severely low	Check fan and ventilation. Allow system to cool.
30	Base Treatment Temperature High (Moderate)		X		The base treatment temperature is high	Check fan and ventilation. Allow system to cool.
31	Base Treatment Temperature High (Severe)	X			The base treatment temperature is severely high	Check fan and ventilation. Allow system to cool.

Code	Message	Critical	Clearable	Warning	Description	Action
32	BRF Treatment Temperature Low (Moderate)		X		Laser module treatment temperature is low	Check fan and ventilation. Allow system to warm up.
33	BRF Treatment Temperature Low (Severe)	X			Laser module treatment temperature is severely low	Check fan and ventilation. Allow system to warm up.
34	BRF Treatment Temperature High (Moderate)		X		Laser module treatment temperature is high	Check fan and ventilation. Allow system to cool.
35	BRF Treatment Temperature High (Severe)	X			Laser module treatment temperature is severely high	Check fan and ventilation. Allow system to cool.
36	LBO Treatment Temperature Low (Moderate)		X		Laser module treatment temperature is low	Check fan and ventilation. Allow system to warm up.
37	LBO Treatment Temperature Low (Severe)	X			Laser module treatment temperature is severely low	Check fan and ventilation. Allow system to warm up.
38	LBO Treatment Temperature High (Moderate)		X		Laser module treatment temperature is high	Check fan and ventilation. Allow system to cool.
39	LBO Treatment Temperature High (Severe)	X			Laser module treatment temperature is severely high	Check fan and ventilation. Allow system to cool.
40	Red Treatment Temperature Low (Moderate)		X		Laser module treatment temperature is low	Check fan and ventilation. Allow system to warm up.
41	Red Treatment Temperature Low (Severe)	X			Laser module treatment temperature is severely low	Check fan and ventilation. Allow system to warm up.
42	Red Treatment Temperature High (Moderate)		X		Laser module treatment temperature is high	Check fan and ventilation. Allow system to cool.
43	Red Treatment Temperature High (Severe)	X			Laser module treatment temperature is severely high	Check fan and ventilation. Allow system to cool.
44	Ambient Temperature Low (Moderate)		X		The ambient temperature is low	Check fan and ventilation. Allow system to warm up.
45	Ambient Temperature Low (Severe)	X			The ambient temperature is severely low	Check fan and ventilation. Allow system to warm up.
46	Ambient Temperature High (Moderate)		X		The ambient temperature is high	Allow system to cool. Reconfigure treatment parameters if necessary
47	Ambient Temperature High (Severe)	X			The ambient temperature is severely high	Allow system to cool. Reconfigure treatment parameters if necessary
48	Treatment Base Temperature Over Maximum		X		OPSL Base Temperature during treatment exceeds Laser module maximum allowable value	Allow system to cool. Reconfigure treatment parameters if necessary
49	Treatment BRF Temperature Over Maximum		X		OPSL BRF Temperature during treatment exceeds Laser module maximum allowable value	Allow system to cool. Reconfigure treatment parameters if necessary

Code	Message	Critical	Clearable	Warning	Description	Action
50	Treatment LBO Temperature Over Maximum		X		OPSL LBO Temperature during treatment exceeds Laser module maximum allowable value	Allow system to cool. Reconfigure treatment parameters if necessary
51	Treatment Temperature Over Maximum (Red Laser modules)		X		Red Laser modules Base Temperature during treatment exceeds Laser module maximum allowable value	Allow system to cool. Reconfigure treatment parameters if necessary
52	Ambient Temperature Over Maximum		X		Ambient Temperature during treatment exceeds maximum allowable value	Allow system to cool. Reconfigure treatment parameters if necessary
56	Aiming Local Light Over (High)		X		Aiming laser output is 100% over the expected value	User to select End Treatment and Return to the Home Screen. Re-access treatment screen and reconfigure treatment parameters. If error repeats- End Treatment and call Service
57	OPSL Treatment Local Light Under (Low)			X	Laser output is 20% under the expected value	User to select End Treatment and Return to the Home Screen. Re-access treatment screen and reconfigure treatment parameters. If error repeats- End Treatment and call Service
58	OPSL Treatment Local Light Over (Low)			X	Laser output is 20% over the expected value	User to select End Treatment and Return to the Home Screen. Re-access treatment screen and reconfigure treatment parameters. If error repeats- End Treatment and call Service
59	OPSL Treatment Local Light Over (Medium)		X		Laser output is 50% over the expected value	User to select End Treatment and Return to the Home Screen. Re-access treatment screen and reconfigure treatment parameters. If error repeats- End Treatment and call Service
60	OPSL Treatment Local Light Over (High)		X		Laser output is 100% over the expected value	User to select End Treatment and Return to the Home Screen. Re-access treatment screen and reconfigure treatment parameters. If error repeats- End Treatment and call Service

Code	Message	Critical	Clearable	Warning	Description	Action
61	Red 60µm Treatment Local Light Under (Low)			X	Laser output is 20% under the expected value	User to select End Treatment and Return to the Home Screen. Re-access treatment screen and reconfigure treatment parameters. If error repeats- End Treatment and call Service
62	Red 60µm Treatment Local Light Over (Low)			X	Laser output is 20% over the expected value	User to select End Treatment and Return to the Home Screen. Re-access treatment screen and reconfigure treatment parameters. If error repeats- End Treatment and call Service
63	Red 60µm Treatment Local Light Over (Medium)		X		Laser output is 50% over the expected value	User to select End Treatment and Return to the Home Screen. Re-access treatment screen and reconfigure treatment parameters. If error repeats- End Treatment and call Service
64	Red 60µm Treatment Local Light Over (High)		X		Laser output is 100% over the expected value	User to select End Treatment and Return to the Home Screen. Re-access treatment screen and reconfigure treatment parameters. If error repeats- End Treatment and call Service
65	Red 200µm Treatment Local Light Under (Low)			X	Laser output is 20% under the expected value	User to select End Treatment and Return to the Home Screen. Re-access treatment screen and reconfigure treatment parameters. If error repeats- End Treatment and call Service
66	Red 200µm Treatment Local Light Over (Low)			X	Laser output is 20% over the expected value	User to select End Treatment and Return to the Home Screen. Re-access treatment screen and reconfigure treatment parameters. If error repeats- End Treatment and call Service
67	Red 200µm Treatment Local Light Over (Medium)		X		Laser output is 50% over the expected value	User to select End Treatment and Return to the Home Screen. Re-access treatment screen and reconfigure treatment parameters. If error repeats- End Treatment and call Service
68	Red 200µm Treatment Local Light Over (High)		X		Laser output is 100% over the expected value	User to select End Treatment and Return to the Home Screen.

Code	Message	Critical	Clearable	Warning	Description	Action
						Re-access treatment screen and reconfigure treatment parameters. If error repeats-End Treatment and call Service
69	Unexpected local light (OPSL Aiming)		X		Laser output was detected when it was not expected	Verify device connections.
70	Unexpected local light (Red 60µm)		X		Laser output was detected when it was not expected	Verify device connections.
71	Unexpected local light (Red 200µm)		X		Laser output was detected when it was not expected	Verify device connections.
72	X-Galvo Spot Position Service Error During Aiming		X		An error occurred within the spot position service regarding the X galvo during aiming beam output	Clear error to continue. Call service if error persists.
73	Y-Galvo Spot Position Service Error During Aiming		X		An error occurred within the spot position service regarding the Y galvo during aiming beam output	Clear error to continue. Call service if error persists.
74	X-Galvo Spot Position Service Error During Treatment		X		An error occurred within the spot position service regarding the X galvo during treatment output	Clear error to continue. Call service if error persists.
75	Y-Galvo Spot Position Service Error During Treatment		X		An error occurred within the spot position service regarding the Y galvo during treatment output	Clear error to continue. Call service if error persists.
76	Spot Size Service F-Galvo		X		An error occurred within the spot size service regarding the F galvo	Clear error to continue. Call service if error persists.
77	Software Watchdog	X			Main PCB controller has been reset or did not synchronize with the SBC.	Reboot. Call service if error persists.
78	Host Communication	X			Communication with the SBC failed.	Reboot. Call service if error persists.
79	Port 1 Fault		X		An error was detected with port 1	Reboot. Call service if error persists.
80	Port 2 Fault		X		An error was detected with port 2	Reboot. Call service if error persists.
91	Footswitch Discrepancy		X		Defective Footswitch connected	Verify footswitch connection.
92	Main DSP Communication	X			Communication with the Main DSP failed.	Call service if error persists.
93	Galvo DSP Communication	X			Communication with the Galvo DSP failed.	Call service if error persists.
108	Firmware Revision Request	X			The Main PCB cannot provide the firmware revision	Call service if error persists.
128	Application Configuration	X			The firmware failed to accept the application configuration	Call service if error persists.
129	System Configuration	X			The firmware failed to accept the system configuration	Call service if error persists.
132	Set Audio	X			The firmware failed to enable or disable the audio	Call service if error persists.
204	Touchscreen Error	X			The Touchscreen was disconnected.	Reboot. Check connections. Call service if error persists.
205	Kill Line Asserted	X			The front-end DIO determined that the kill lines were asserted.	Reboot. Call service if error persists.

Code	Message	Critical	Clearable	Warning	Description	Action
206	<b>SLA Detached</b>	X			The SLA is not attached	Verify connection to slit lamp.
207	<b>Pattern Locked</b>			X	The pattern cannot be modified at this time. Certain patterns can only be modified in Standby mode.	Press Ready button on Touchscreen to return to Standby mode before modifying patterns.
208	<b>System Busy</b>			X	The user cannot start a treatment because the system has a pending message.	User to select End Treatment and Return to the Home Screen. Re-access treatment screen and reconfigure treatment parameters. If error repeats- End Treatment and call Service
209	<b>Footswitch in Standby</b>			X	The user pressed the footswitch in standby mode.	Press Standby button on Touchscreen to enter Ready mode.
210	<b>No output available</b>		X		The user cannot become Ready because the SLA is detached and all external ports are empty.	Check SLA connection. Reboot. Call service if error persists.
211	<b>Must use LIO</b>		X		The user cannot deselect the currently selected LIO because the SLA is not attached.	Check LIO or SLA connection. Reboot. Call service if error persists.
212	<b>Attachment CRC Error</b>		X		The 1-wire data on an attachment (LIO or SLA) has an invalid CRC value.	Check LIO or SLA connection. Reboot. Call service if error persists.
213	<b>Laser Color Mismatch</b>		X		The 1-wire data on an attachment (LIO or SLA) says that the device does not support the system laser's color	Check LIO or SLA connection. Reboot. Call service if error persists.
214	<b>Bad Attachment Version</b>		X		The 1-wire data on an attachment (LIO or SLA) has an unsupported format version.	Check LIO or SLA connection. Reboot. Call service if error persists.
215	<b>Cannot Load Favorite: Not Single Spot</b>			X	The system cannot load the selected favorite because the SLA is not attached, and the favorite is not for the single-spot pattern.	Select a different favorite or set parameters using the Touchscreen.
216	<b>Cannot Load Favorite: No Output</b>			X	The system cannot load the favorite because no attachments (LIO or SLA) are attached.	Select a different favorite or set parameters using the Touchscreen or attach an LIO or SLA.
217	<b>Cannot Load Favorite: No LIO</b>			X	The system cannot load the favorite because it requires an LIO but no LIO is attached	Select a different favorite or set parameters using the Touchscreen or attach an LIO.
218	<b>Cannot Load Favorite: Bad Pattern</b>			X	The system cannot load the favorite because it refers to a pattern that is not in the system.	Select a different favorite or set parameters using the Touchscreen.
219	<b>Database Error</b>	X			The system cannot function because a database operation returned an error code.	Reboot. Call service if error persists.
220	<b>Laser Warmup Timeout</b>	X			The back-end could not warm the lasers up quickly enough.	Reboot. Call service if error persists.
221	<b>3D Controller Error</b>		X		The 3D controller is disconnected or there was an error attempting to	Unplug and plug in the 3D controller USB connector

Code	Message	Critical	Clearable	Warning	Description	Action
					detect it.	to reset. Reboot. Call service if error persists.
222	<b>Invalid Attachment Calibration</b>	X			The calibration file is missing, not readable, or incomplete. Check the log file for the exact problem.	Reboot. Call service if error persists.
223	<b>Treatment Incomplete</b>		X		This warning occurs when a partial treatment occurs for any reason. (The most common reason is the user released the foot switch too soon, but partial treatments could also be caused by errors.)	User to select End Treatment and Return to the Home Screen. Re-access treatment screen and reconfigure treatment parameters. If error repeats- End Treatment and call Service
225	<b>Cannot Save Favorite</b>		X		Error occurs while saving favorite information to file	Check name provided. Check for duplicates.
226	<b>POST Failed (OPSL)</b>	X			Power On Self-test failure due to OPSL laser initialization error	Reboot. Call service if error persists.
228	<b>POST Laser Failure</b>	X			Power On Self-test failure due to both OPSL laser and one or more Red lasers initialization error	Reboot. Call service if error persists.
230	<b>MM controller disconnected</b>	X			Communication with the MM controller failed.	Reboot. Call service if error persists.
231	<b>Invalid 3D Controller</b>	X			An invalid 3D controller is connected.	Power off the system, disconnect the invalid 3D controller from the system and then power on the system.

## Calibration Procedure

Regulatory agencies require that manufacturers of US FDA CDRH Class II and IV and European IEC 60825 Class 2 and 4 medical lasers supply customers with power calibration instructions.

Calibration must be performed by an engineer or technician qualified to work on energized electronic laser equipment.

### ***Disclaimer Warning***

Calibration of the system is a service procedure to be performed only by certified personnel. Adjustment by anyone other than certified personnel voids any existing manufacturer's warranty on the instrument and can result in serious personal injury.

### ***Calibration Instructions***

There is no need to open the system for calibration. In fact calibration should be done with the covers on.

Tools Required:

- USB keyboard and mouse
  - NIST-traceable Gentec calibrated optical power meter
  - Power meter to chinrest adapter
1. De-energize the system.
  2. Connect the keyboard and mouse to the USB port.
  3. Attach the power meter to chinrest adapter.
  4. Install the optical power meter.
  5. Re-energize and start up the system.
  6. Navigate to the Service/Calibration software and enter Service Mode.
  7. Align the optical power meter using the aiming beam.
  8. Calibrate the system as per DC-03366 service manual.
  9. Shut down and de-energize the system, as indicated in the <System Start-up and Shut-down> section in this manual.
  10. Remove the keyboard and mouse.
  11. Re-energize and start up the system.
  12. Verify the calibration using the optical power meter.

If successful, shut down the system and remove the power meter and chinrest adapter. If not successful, repeat the calibration procedure.

## System Relocation Instructions

To move the system to another location:

1. Ensure that the wall circuit breaker is turned off and the key switch is in the OFF position.
2. Remove the power cable from the wall outlet and the system main power receptacle.
3. If a remote door interlock is utilized, remove the interlock plug and cable from the interlock port and transport separately.
4. Disconnect the footswitch cable from the footswitch port and transport separately. Never drag the footswitch.
5. Position the console a minimum of 15 cm ( $\approx$  6 in) away from walls, furniture or other equipment. Adequate space around the console ensures proper air circulation for system cooling purposes.
6. If there are changes in environmental conditions (temperature or humidity) allow system to acclimate for 4 hours prior to use.

## Room Preparation

1. Verify that the system power cable and plug are correctly connected, as instructed in the preoperative instructions.
2. Verify environmental conditions are within limits for operation.



### NOTE

*For systems configured with an electrical wall circuit breaker, always place the electrical wall circuit breaker in the off position before inserting the plug into the receptacle.*

3. Verify that the electrical service is turned on.
4. Verify that the laser warning sign has been posted outside of the treatment room door.
5. Ensure that all attending personnel in the treatment room are wearing appropriate eye protection goggles or eyeglasses.

## Instructions for Use

### *Intended Use Environment*

The intended Use Environment of the laser system is as follows:

- Professional Healthcare Facility Environment
- Physician offices, clinics, multiple treatment facilities, hospitals except for near active HF surgical equipment and the RF shielded room of an ME system for magnetic resonance imaging, where the intensity of EM disturbances is high.

### *Patient Environment*

The Patient Environment is defined by the following:

- When the patient or inspector comes in contact with the devices (including the connecting devices)
- When the patient or inspector touches the person that comes into contact with the devices (including the connecting devices).

In the patient environment (shown below) , use the device conforming to IEC 60601-1 standard. If you are compelled to use any device not conforming to the standard, use an insulation transformer which conforms to IEC 60601-1 standard.

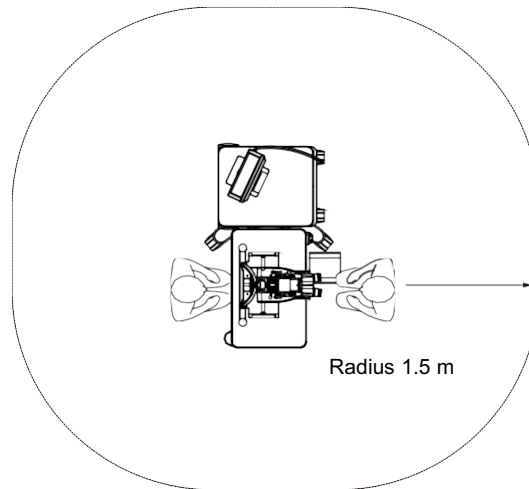

Devices applicable to the use in patient environment:

- Insulation transformer

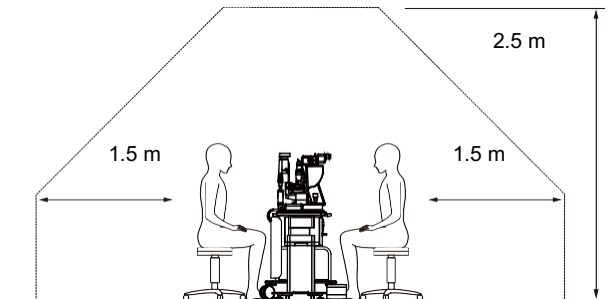

## CAUTION

- *Do not use the power strip in the patient environment.*
- *Do not connect an additional power strip or an extension cord to the system.*
- *Do not connect any device which is not recognized as a component of the system.*
- *Use the insulation transformer conforming to IEC 60601-1*

## Electromagnetic Compatibility

Applicable to PASCAL Synthesis Laser Systems with serial numbers starting with “80” (eg 80xxxxxx).

This product conforms to the EMC standard (IEC 60601-1-2: 2014). The expected electromagnetic environment for the whole life cycle is professional healthcare facility environment.

- a) MEDICAL ELECTRICAL EQUIPMENT needs special precautions regarding EMC and needs to be installed and put into service according to the EMC information provided in the ACCOMPANYING DOCUMENTS.
- b) Portable and mobile RF communications equipment can affect MEDICAL ELECTRICAL EQUIPMENT.
- c) The EQUIPMENT or SYSTEM should not be used adjacent to or stacked with other equipment. If adjacent or stacked use is necessary, the EQUIPMENT or SYSTEM should be observed to verify normal operation in the configuration in which it will be used.
- d) The use of the ACCESSORY, transducer or cable with EQUIPMENT and SYSTEMS other than those specified may result in increased EMISSION or decreased IMMUNITY of this EQUIPMENT and result in improper operation.
- e) Do not use the devices generating electromagnetic waves within 30cm from all the parts of the instrument and system. Those devices may have influence on this product.

Item	Cable Shielded	Ferrite Core	Length (m)
<b>ACCESSORIES</b>			
HEAD UP DISPLAY SYSTEM HUD-1 Module	-	-	-
PASCAL Laser Indirect Ophthalmoscope (LIO)	-	-	-
<b>CABLES</b>			
AC power cord (for SLIT LAMP)	Not Used	Not Used	1.8
AC power cord (for LASER CONSOLE)	Not Used	Not Used	3.6
USB Cable (Unterminated)	Used	Not Used	N/A
USB Cable (for 3D Mouse)	Used	Not Used	1.9
USB Cable (for Monitor)	Used	Not Used	1.9
VGA Cable (for Monitor)	Not Used	Not Used	1.9
SIP/SOP Cable (for Footswitch)	Not Used	Not Used	2.9
SIP/SOP Cable (for LIO)	Not Used	Not Used	1.9
USB Cable (for HUD-1)	Not Used	Not Used	1.8
HDMI Cable (for HUD-1)	Not Used	Not Used	1.8

Like other electrical medical devices, PASCAL Synthesis Ophthalmic Scanning Laser System require special precautions to ensure electromagnetic compatibility (EMC) with other electrical medical devices. To ensure EMC, your system must be installed and operated according to the EMC information provided in this manual.



## NOTE

*PASCAL Synthesis Ophthalmic Scanning Laser System have been designed and tested to comply with IEC 60601-1-2:2014 requirements for EMC with other devices.*

*This equipment has been tested and found to comply with the limits for a Class B digital device, pursuant to Part 15 of the FCC Rules. These limits are designed to provide reasonable protection against harmful interference in a residential installation. This equipment generates, uses and can radiate radio frequency energy and, if not installed and used in accordance with the instructions, may cause harmful interference to radio communications. However there is no guarantee that interference will not occur in a particular installation. If this equipment does cause harmful interference to radio or television reception, which can be determined by turning the equipment off and on, the user is encouraged to try to correct the interference by one or more of the following measure:*

- *Reorient or relocate the receiving antenna.*
- *Increase the separation between the equipment and receiver.*
- *Connect the equipment into an outlet on a circuit different from that to which the receiver is connected.*
- *Consult the dealer or an experienced radio/TV technician for help.*

<b>Guidance and manufacturer's declaration - electromagnetic emissions</b>		
<p>The PASCAL Synthesis Ophthalmic Scanning Laser System is intended for use in the electromagnetic environment specified below. The customer or the user of the PASCAL Synthesis Ophthalmic Scanning Laser System should assure that it is used in such an environment.</p>		
<b>Emissions test</b>	<b>Compliance</b>	<b>Electromagnetic environment - guidance</b>
RF emissions CISPR 11	Group 1	<p>The PASCAL Synthesis Ophthalmic Scanning Laser System uses RF energy only for its internal function. Therefore, its RF emissions are very low and are not likely to cause any interference in nearby electronic equipment.</p> <p>The PASCAL Synthesis Ophthalmic Scanning Laser System is suitable for use in all establishments including domestic and those directly connected to the public low-voltage power supply network that supplies buildings used for domestic purposes.</p>
RF emissions CISPR 11	Class B	
Harmonic emissions IEC61000-3-2	Class A	
Voltage fluctuations/ flicker emissions IEC61000-3-3	Complies	

<b>Guidance and manufacturer's declaration - electromagnetic immunity</b>			
The PASCAL Synthesis Ophthalmic Scanning Laser System is intended for use in the electromagnetic environment specified below. The customer or the user of the PASCAL Synthesis Ophthalmic Scanning Laser System should assure that it is used in such an environment.			
<b>Immunity test</b>	<b>IEC 60601 test level</b>	<b>Compliance level</b>	<b>Electromagnetic environment - guidance</b>
Electrostatic discharge (ESD) IEC 61000-4-2	± 8 kV contact ± 15 kV air	± 8 kV contact ± 15 kV air	Floors should be wood, concrete or ceramic tile. If floors are covered with synthetic material, the relative humidity should be at least 30%.
Electrical fast transient/burst IEC 61000-4-4	± 2 kV for power supply lines ± 1 kV for input/output lines Repetition frequency 100kHz	± 2 kV for power supply lines ± 1 kV for input/output lines Repetition frequency 100kHz	Main power quality should be that of a typical commercial or hospital environment.
Surge IEC 61000-4-5	± 1 kV line(s) to line(s) ± 2 kV line(s) to earth	± 1 kV line(s) to line(s) ± 2 kV line(s) to earth	Main power quality should be that of a typical commercial or hospital environment.
Voltage dips, short interruptions and Voltage variations on power supply input lines IEC 61000-4-11	<5% $U_t$ (>95% dip in $U_t$ ) for 0.5 cycle (with phase angle 0°, 45°, 90°, 135°, 180°, 225°, 270° and 315°) <5% $U_t$ (>95% dip in $U_t$ ) for 1 cycle 70% $U_t$ (30% dip in $U_t$ ) for 25/30 cycles <5% $U_t$ (>95% dip in $U_t$ ) for 5 sec	<5% $U_t$ (>95% dip in $U_t$ ) for 0.5 cycle (with phase angle 0°, 45°, 90°, 135°, 180°, 225°, 270° and 315°) <5% $U_t$ (>95% dip in $U_t$ ) for 1 cycle 70% $U_t$ (30% dip in $U_t$ ) for 25/30 cycles <5% $U_t$ (>95% dip in $U_t$ ) for 5 sec	Main power quality should be that of a typical commercial or hospital environment. If the user of the PASCAL Synthesis Ophthalmic Scanning Laser System requires continued operation during main power interruptions, it is recommended that the SL-PASCAL Synthesis Ophthalmic Scanning Laser System be powered from an uninterruptible power supply or battery.
Power frequency (50/60 Hz) magnetic field IEC 61000-4-8	30 A/m	30 A/m	Power frequency magnetic fields should be at levels characteristic of a typical location in a typical commercial or hospital environment.
NOTE $U_t$ is the a.c. main voltage prior to application of the test level.			

<b>Guidance and manufacturer's declaration - electromagnetic immunity</b>			
The PASCAL Synthesis Ophthalmic Scanning Laser System is intended for use in the electromagnetic environment specified below. The customer or the user of the PASCAL Synthesis Ophthalmic Scanning Laser System should assure that it is used in such an environment.			
<b>Immunity test</b>	<b>IEC 60601-1-2:2014 test level</b>	<b>Compliance level</b>	<b>Electromagnetic environment - guidance</b>
<p>Conducted RF IEC 61000-4-6</p> <p>Radiated RF IEC 61000-4-3</p>	<p>3 Vrms 150kHz to 80MHz</p> <p>10 V/m 80MHz to 2.7GHz</p> <p>Proximity electromagnetic field from radio communication equipment a)</p>	<p>3 Vrms 150kHz to 80MHz</p> <p>10 V/m 80MHz to 2.7GHz</p> <p>Proximity electromagnetic field from radio communication equipment a)</p>	<p>Portable and mobile RF communications equipment should be used no closer to any part of the PASCAL Synthesis Ophthalmic Scanning Laser System, including cables, than the recommended separation distance calculated from the equation applicable to the frequency of the transmitter.</p> <p>Recommended separation distance <math>d = \frac{6}{E} \sqrt{P}</math></p> <p>where P is the maximum output power rating of the transmitter in watts (W) according to the transmitter manufacturer, d is the recommended separation distance in meters (m), and E is the radiation electromagnetic field level in volt/meter (V/m).</p>
NOTE 1	These guidelines may not apply in all situations. Electromagnetic propagation is affected by absorption and reflection from structures, objects and people.		

a The table below shows the proximity electromagnetic field from radio communication equipment.

Test frequency [MHz]	Band [MHz]	Equipment	Modulation	Maximum output[W]	Distance [m]	Immunity test value [V/m]
385	380-390	TETRA 400	Pulse modulation 18Hz	1.8	0.3	27
450	430-470	GMRS 460 FRS 460	FM +/-5kHz 1kHz sine	2	0.3	28
710	704-787	LTE Band 13, 17	Pulse modulation 217Hz	0.2	0.3	9
745						
780						
810	800-960	GSM 800/900 TETRA 800 iDEN820 CDMA850 LTE Band 5	Pulse modulation 18Hz	2	0.3	28
870						
930						
1720	1700-1990	GSM 1800 CDMA 1900 GSM 1900 DECT LTE Band 1,3,4,25 UMTS	Pulse modulation 217Hz	2	0.3	28
1845						
1970						
2450	2400-2570	Bluetooth WLAN 802.11 b/g/n RFID 2450 LTE Band7	Pulse modulation 217Hz	2	0.3	28
5240	5100-5800	WLAN 802.11 a/n	Pulse modulation 217Hz	0.2	0.3	9
5500						
5785						

---

## Ophthalmology References

1. The Diabetic Retinopathy Study Research Group. Photocoagulation Treatment of Proliferative Diabetic Retinopathy Clinical application of diabetic retinopathy-study (DRS) findings, DRS report number 8. *Ophthalmology* 1981; 88:583-600.
2. Quigley HA. Long Term Follow-up of Laser Iridotomy. *Ophthalmology* 1981; 88:218- 114
3. Fleischman JA, Swartz MA, Dixon JA. Krypton Laser Endophotocoagulation An Intraoperative Trans-Pars Plana Technique *Archives of Ophthalmology*, 99: 1610- 1612, 1981
4. Ritch R, Podos SM. Krypton Laser Treatment of Angle Closure Glaucoma Perspectives in *Ophthalmology* Vol.4, No.4, June,1980
5. Schwartz AL, et al. AI. Krypton Laser Trabecular Surgery in Uncontrolled Phakic Open Angle Glaucoma *Ophthalmology* Vol.88 No.3, March 1981.
6. *Ophthalmic Laser Therapy Posterior Segment Laser Section Current Techniques Proliferative Diabetic Retinopathy*. Edited by Michael J. Bradbury, Vol.1,No.2, 121-129
7. L'Esperance FA, *Ophthalmic Lasers Third Edition Photocoagulation of Ocular Disease: Application and Technique*. (1988)
8. Kurata F, et al. Intraocular pressure the day of Krypton Laser Trabeculoplasty in Primary Open-angle Glaucoma *Ophthalmology* 89:338, 1980
9. Thomas JV, Simmons R and Belcher CD III. Complications of Krypton Laser Trabeculoplasty *Glaucoma* 4:50, 1982
10. Wise JB, Errors in Laser Spot Size in Laser Trabeculoplasty *Ophthalmology*, 91:186, 1984
11. Kanski JJ, *Clinical Ophthalmology, Second Edition*. Butterworths, 1989

## General information on Usage

### *Intended Patient Population*

The patient who undergoes an examination by this equipment must maintain concentration during the treatment and adhere to the following instructions:

- *Fix the face to the chinrest, forehead rest.*
- *Keep the eye open.*
- *Understand and follow instructions when undergoing a treatment.*

### Intended User Profile

This device must be used by a physician only.

### **Accessories**

Part Number	Description
EC-03288	Power Cord for Console and Slit lamp
EC-06340	10.4" LCD monitor
SA-06479	3D mouse controller (Purchased Separately)
EC-06434	Cable Assy., External LCD Bundle
EC-07032	Cartridge Fuse, 2 Amp Slo Blow
EC-06433	Footswitch, covered
EC-06361	Remote Interlock plug

---

## Warranty Information

Iridex Corporation warrants PASCAL Synthesis Ophthalmic Scanning Laser System to be free from defects in material and workmanship at the original purchaser's location for 12 months.

In order to comply with this warranty, all internal adjustments or modifications must be made by Iridex Corporation-certified personnel or with the express permission of the Iridex Corporation Service Department. The warranty does not apply in the event of misuse, negligence or accidental damage.

The liability of Iridex Corporation under valid warranty claims is limited to repair or replacement at Iridex Corporation's plant or purchaser's place of business (or, if not practicable, a refund of the purchase price, all at the option of Iridex Corporation).

There are certain other limitations that apply to Iridex Corporation's warranty. Reference should be made to the terms and conditions of sale attached to Iridex Corporation's purchase agreement. Warranty terms may be different by region based on contractual agreements.

### ***Warranty Shipments, Returns, and Adjustments***

A warranty claim must be made promptly and must be received during the applicable warranty period by Iridex Corporation. If it becomes necessary to return a product for repair and/or adjustments, authorization from Iridex Corporation must be obtained. Instructions as to how and where products should be shipped will be provided by Iridex Corporation. Any product or component returned for examination and/or warranty repair shall be sent insured and prepaid via the means of transportation specified by Iridex Corporation. Shipping charges for all products or components replaced or repaired under warranty shall be the sole responsibility of the purchaser. In all cases, Iridex Corporation has sole responsibility for determining the cause and nature of failure and Iridex Corporation's determination with regard thereto will be final.

The foregoing Warranty is exclusive and in lieu of all other warranties, whether written, oral or implied, and shall be the purchaser's sole remedy and Iridex Corporation's sole liability on contract or warranty or otherwise for the product. Iridex Corporation disclaims any implied warranty or merchantability or fitness for a particular purpose. In no event shall Iridex Corporation be liable for any incidental or consequential damages arising out of or in connection with the use or performance of the goods delivered hereunder. The essential purpose of this provision is to limit Iridex Corporation's potential liability arising out of this sale.

## Decontamination of Returned Equipment

To comply with United States postal and transportation law, equipment shipped to Iridex Corporation for repair or return must be properly decontaminated with a chemical germicide that is commercially available and cleared for sale as a Hospital Disinfectant. To ensure that all equipment has been properly decontaminated, a signed Decontamination Certificate (provided in this section) must be enclosed in the package.

If equipment is received without a Decontamination Certificate, Iridex Corporation will assume the product is contaminated and will assess the customer with decontamination costs.

Any inquiries should be directed to the Iridex Corporation Service Department. These include service of a device, assistance with troubleshooting the device and ordering accessories.

## US Technical Service Information

Iridex Corporation  
1212 Terra Bella Avenue  
Mountain View, California 94043  
USA

Phone: +1.650.940.4700

Fax : +1.650.962.0486

[PASCALservice@iridex.com](mailto:PASCALservice@iridex.com)

## Decontamination Certification

Under the provisions of Postal Law, Title 18, United States Code, Section 1716 and Department of Transportation regulations contained in CFR 49, Part 173.386 and 173.387, "etiologic agents, diagnostic specimens and biological products...are nonmailable..."

The undersigned therefore certifies that the IRIDEX Corporation equipment being returned herein by

\_\_\_\_\_  
Individual/Institution

\_\_\_\_\_  
City, State/Province, Country

Has undergone decontamination with a commercially available germicide cleared for use as a Hospital Disinfectant and is clean and free from biohazards, including – but not limited – human or animal blood, tissue **or** tissue fluids **or** components thereof.

The undersigned also agrees to reimburse Iridex Corporation for any costs incurred in decontaminating the enclosed equipment, in the event said item is received by Iridex Corporation in a contaminated condition.

Model: PASCAL Synthesis Ophthalmic Scanning Laser System

Wavelength:  532 nm  577 nm

Serial Number: \_\_\_\_\_

Iridex Corporation  
RMA Number: \_\_\_\_\_

Position/Title: \_\_\_\_\_

Name (Printed): \_\_\_\_\_

\_\_\_\_\_  
Signature

\_\_\_\_\_  
Date (DD/MM/YYYY)

## Disposal

When disposing of the instrument and/or parts, follow local regulations for disposal and recycling or contact your local representative for detailed disposal information.



This symbol is applicable for EU member countries only.  
To avoid potential damage to the environment and possibly human health, this instrument should be disposed of (i) for EU member countries - in accordance with WEEE (Directive on Waste Electrical and Electronic Equipment), or (ii) for all other countries, in accordance with local disposal and recycling laws.

This product contains a coin cell.  
You cannot replace batteries by yourself. When you need to replace and/or dispose batteries, contact your dealer or Iridex listed on the back cover.

  
**NOTE**



**EU Battery Directive**  
This symbol is applicable for EU members states only.

Battery users must not dispose of batteries as unsorted general waste, but treat properly.  
If a chemical symbol is printed beneath the symbol shown above, this chemical symbol means that the battery or accumulator contains a heavy metal at a certain concentration.  
This will be indicated as follows:  
Hg: mercury (0.0005%), Cd: cadmium (0.002%), Pb: lead (0.004%)  
These ingredients may be seriously hazardous to human and the global environment.

This product contains a CR Lithium Battery which contains Perchlorate Material-special handling may apply.  
See <https://dtsc.ca.gov/perchlorate/>  
Note: This is applicable to California, USA only

## Pattern Scanning Laser Trabeculoplasty (PSLT) (optional)

### **Indications for Use:**

Pattern Scanning Laser Trabeculoplasty (PSLT) software is intended for use with the PASCAL Synthesis for procedures in trabeculoplasty in Open Angle Glaucoma.

### **Description:**

Pattern Scanning Laser Trabeculoplasty or PSLT is an advanced tissue-sparing laser treatment for reducing intraocular pressure. PSLT provides a rapid, precise, and minimally traumatic (sub-visible) computer-guided treatment that applies a sequence of patterns onto the trabecular meshwork. Automated rotation of consecutive patterns ensures that treatment steps are precisely placed around the trabecular meshwork without overlap or excessive gaps.

When the PSLT pattern is selected, the pattern is delivered when you depress the footswitch, after which the system automatically rotates the pattern clockwise. If the 360-degree treatment plan is selected, the pattern rotates a full 360 degrees before treatment is automatically terminated. If the 180-degree treatment plan is selected, the pattern rotates 180 degrees before treatment is automatically terminated.

Establish starting location for PSLT pattern.

Titrate to set desired Power.

Align to trabecular meshwork using <Curvature>.

"<Treatment Complete>" displays in the <PSLT Treatment> window, and the system enters STANDBY mode. Press <OK> to return to the Anterior Treatment screen.

Additional treatments can be initiated after returning to the Anterior Treatment screen.

Exposure Time	Spot Diameter	Curvature	Treatment Plan	Power
5 ms (Titrate off); 10 ms (Titrate on)	100 µm	0.00-3.00	360° or 180°	0-1500 mW

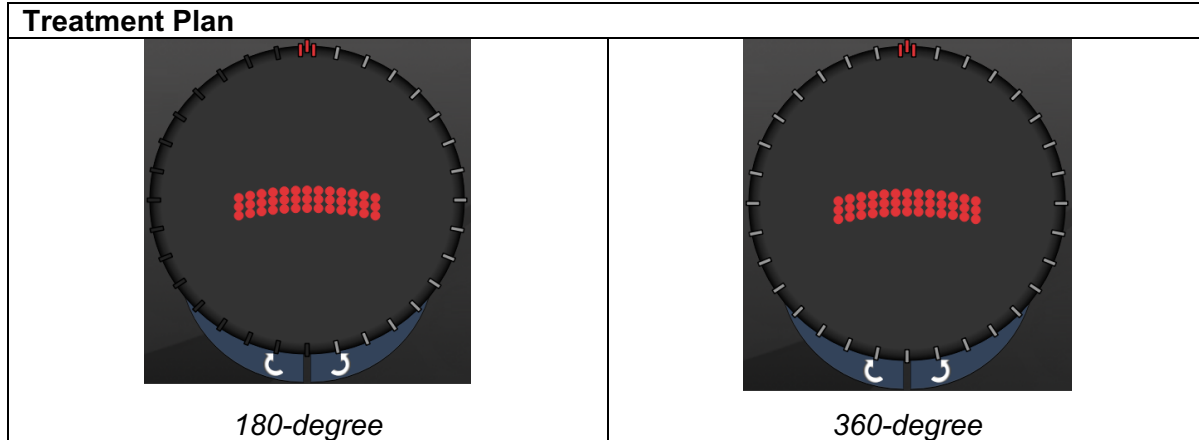

### NOTE

*For use with a gonioscopic lens of 1.0X magnification.*

*The PSLT pattern appears in the center of the field of view and not in the periphery. Use contact lens to set location.*

*If, during the course of the treatment, the footswitch is released before the entire pattern is delivered, "<Treatment Complete>" and "<NN Incomplete Segments>" (where "<NN>" represents the number of segments that were not completed) display in the < PSLT Treatment> summary window.*

*Use arrows or 3D Controller to rotate pattern to desired treatment location.*





### NOTE

- *PSLT is available only for 532 and 577 nm*

### ***Anterior Pattern Descriptions/Pattern Parameters***

There are three anterior pattern types. The PSLT 3 row, Array (20ms default) and Single Spot patterns are available in the Anterior Treatment screen.

<b><i>PSLT 3 Row</i></b>		<b><i>Array</i></b>	
<b><i>Single Spot</i></b>			

***Primary Pattern***

See the section “Posterior Pattern description/Parameters” for the detailed information on the Single Spot pattern.



#### **NOTE**

- *The Endpoint Management feature is not available in the Anterior Treatment*
- *PSLT is available only for 532 and 577 nm*

## Array

	Primary pattern	Secondary pattern
Array		

## General Use

- retina tears and retina detachments

Pattern	Spot Diameter ( $\mu\text{m}$ )	Spacing
Array	50 (2x2 or smaller),	0.00 $\emptyset$ to 3.00 $\emptyset$
	100	
	200	
	400	0.00 $\emptyset$ to 1.50 $\emptyset$

The Array (20 ms default) pattern is selectable in a variety of shapes and sizes up to a maximum of 9 spots, including square arrays, rectangle arrays, vertical and horizontal lines of up to 3 spots, and a single spot. Spot diameter and spacing settings are also adjustable.

To select the Array pattern shape and size, drag your finger horizontally, vertically, or diagonally across the pattern, or press one of the quick-select buttons at the bottom of the secondary pattern screen. To select the pattern orientation, press <Rotate> button at the bottom of the screen.

**PSLT 3 Row**

	Primary pattern	Secondary pattern
PSLT 3 Row		Not available

**General Use**

- Trabeculoplasty

The PSLT 3 Row pattern is selectable in various orientations. To select the pattern orientation, press <Rotate> button at the bottom of the screen. The pattern spacing is fixed, but curvature is adjustable.